

City of Sand Point Council Meeting



Workshop: Tuesday, April 12, 2016 – 2:00 p.m.

Meeting: Tuesday, April 12, 2016 – 7:00 p.m.

CALL TO ORDER

ROLL CALL

CITY OF SAND POINT

(packet will be available on website April 8, 2016
www.sandpointak.com)



MAYOR

Mayor Glen Gardner Jr. - Office Exp. 2017

COUNCIL MEMBERS

Danny Cumberlidge	Seat A - Exp. 2016
Allan Starnes	Seat B - Exp. 2017
Shirley Brown	Seat C - Exp. 2016
Jack Foster Jr.	Seat D - Exp. 2017
Marita Gundersen	Seat E - Exp. 2018
Emil Mobeck	Seat F - Exp. 2018

SAND POINT CITY COUNCIL MEETING AGENDA CITY CHAMBERS

Regular Meeting

Tuesday, April 12, 2016 7:00 pm

**CALL TO ORDER
ROLL CALL
APPROVAL OF AGENDA
CONSENT AGENDA:**

1. Minutes: Minutes of Regular Meeting on March 8, 2016

REPORTS:

1. Finance Officer
2. Administrator
3. DPS Director
4. Fire Chief
5. Public Works Director
6. Harbor Master
7. Student Representative

HEARINGS, ORDINANCES AND RESOLUTIONS:

1. Resolution 16-02: Approving Annexation Petition Submission to LBC

OLD BUSINESS:

1. ATV Code of Ordinances

NEW BUSINESS

**PUBLIC COMMENTS
COUNCIL COMMENTS
ADJOURNMENT**

THERE IS A WORKSHOP FOR THIS MEETING AT 2 P.M. – SAME DAY IN CITY CHAMBERS

POSTED 04/06/16

CALL TO ORDER:

The regular meeting of the Sand Point City Council was held Tuesday, March 8, 2016 in the Sand Point Council Chambers. Mayor Glen Gardner, Jr. called the meeting to order at 7:00 p.m.

ROLL CALL:

Glen Gardner, Jr.	Mayor	Present
Danny Cumberlidge	Seat A	Present
Allan Starnes	Seat B	Present
Shirley Brown	Seat C	Present
Jack Foster, Jr.	Seat D	Absent - excused
Marita Gundersen	Seat E	Present
Emil Mobeck	Seat F	Present

A quorum was established.

Staff in attendance:

Andy Varner, Administrator
Shannon Sommer, City Clerk
Krista Galvin, Finance Officer

APPROVAL OF AGENDA:

Mayor Glen Gardner, Jr. requested a motion to approve the agenda.
MOTION: Councilperson Shirley Brown made a motion to adopt the agenda.
SECOND: Councilperson Marita Gundersen seconded the motion.
VOTE: Motion passed unanimously.

APPROVAL OF CONSENT AGENDA:

1. Minutes of February 9, 2016 Regular Meeting Minutes.
Mayor Glen Gardner, Jr. requested a motion to approve the consent agenda.
MOTION: Councilperson Marita Gundersen made a motion to adopt the consent agenda.
SECOND: Councilperson Danny Cumberlidge seconded the motion.
VOTE: Motion passed unanimously.

REPORTS:

Finance Officer- Krista Galvin

Finance Officer Krista Galvin reported that as of January 2015, we received \$21,798.52 in Raw Fish Tax and \$60,942.89 in Sales Tax. She included a bank balance.

Administrator - Andy Varner

Administrator Andy Varner reported Mayor Gardner and Lobbyist Mark Hickey and himself had several meetings regarding the City’s airport recertification. DOT pushed the time frame to around August. One possibility they explored was the “Gustavus model,” where the State has a separate maintenance contract for the airport, and another for the 139 requirements. Administrator Varner attached an updated project timeline for the dock replacement, DOT and PND will visit for a site visit and assessment, the plan to building another dock alongside the existing one is still in place. Mayor Gardner and himself also spoke with Commissioners and legislatures about community jail funding. The City has hired a new Water/Sewer Operator named Allen Young. ANTHC is considering pushing back the Kelly Avenue Outfall Line replacement due to design and how to do the replacement around the beach with equipment. CRW made a site visit and are close to finishing the Water/Sewer Master Plan, they will use the report for upgrades and capital projects using USDA dollars. There is also a timeline for the GCI fiber optic upgrade included for the packet.

Mayor - Glen Gardner, Jr.

Mayor Gardner stated he would like to talk about Street lights during April meetings workshop. The Juneau meetings went good and he acknowledged Lobbyist Hickey's help. This year's SWAMC meeting went well and it was well attended, the Governor made a captivating speech during the first day's lunch. There were presentations on fisheries, ocean acidifications, education and broadband.

Department of Public Safety - Chief John Lucking, Jr.

Manager of Public Safety John Lucking, Jr. report included in packet.

Public Works Director – David Stokes

Public Works Director David Stokes report included in packet.

Harbor Master - Richard Kochuten, Sr.

Harbor Master Richard Kochuten, Sr. reported hauling and storing boats has been slow, they have done oil changes in the machines, did repair work on the City dock, making dump runs on a regular basis, they hauled building materials to the Fish and Game duplex, the staff are still building bilge blocks. Building Maintenance Kenneth Spjut continues to install cameras around the harbor. They started to clear storage area for the new city dock installation, surveyors were in town surveying the area and were going to do the soundings.

Mayor Gardner asked Harbor Master Kochuten if float A still had light issues. Harbor Master Kochuten replied it is and Water/Sewer Supervisor Allen Hill was going to check the problem. Councilperson Shirley Brown asked if someone was planning to retire, he replied at the end of April, one of the Night watchman.

HEARINGS, ORDINANCES, AND RESOLUTIONS: None.

OLD BUSINESS: None.

NEW BUSINESS:

1. Clean-up Donation Request

City Clerk Shannon Sommer will write donation letters and the City will donate same as last year.

2. QTT Earth Day Fair Donation Request

MOTION: Councilperson Shirley Brown made a motion to donate 4-\$50 gift cards and ALPAR garbage bags to the QTT Earth Day Fair.

SECOND: Councilperson Emil Mobeck seconded the motion.

VOTE: Motion passed unanimously.

3. FY15 Audit Results

Administrator Varner stated BDO's Michelle Drew included a memo for our audit. The General Fund is good, the City did a good job turning around the Bingo fund, BDO made some changes to expenses and revenues (especially the PERS accounts), the boat harbor revenue did not fully cover the cost of the new renovation, due mainly to depreciation of the new asset. We still need to watch the Water/Sewer/Refuse funds as their revenues don't cover the expenses.

4. KSDP Resolution

Administrator Varner will write a letter of support for KSDP.

5. Building Permit: GCI

MOTION: Councilperson Shirley Brown made a motion to accept the Building Permit: GCI.

SECOND: Councilperson Allan Starnes seconded the motion.

VOTE: Motion passed unanimously.

PUBLIC COMMENTS: None.

COUNCIL COMMENTS: None.

ADJOURNMENT:

MOTION: Councilperson Marita Gundersen made a motion to adjourn.

SECOND: Councilperson Danny Cumberlidge seconded the motion.

The meeting adjourned at 7:28 PM.

Glen Gardner, Jr., Mayor

ATTEST:

Shannon Sommer, City Clerk

REPORTS

FINANCE OFFICER

**City of Sand Point
Raw Fish Tax Revenue**

	<u>FY10</u>	<u>FY11</u>	<u>FY12</u>	<u>FY13</u>	<u>FY14</u>	<u>FY15</u>	<u>FY16</u>
June	89,371.73	217,340.55	July	98,195.23	156,655.84	121,976.31	110,509.71
July	128,368.96	139,818.08	August	68,242.04	137,107.36	48,575.15	94,822.69
August	78,457.48	117,033.81	September	71,393.24	53,307.44	64,362.76	62,297.79
September	80,983.80	79,043.91	October	74,240.08	41,610.64	32,213.32	76,878.70
October	46,603.74	74,929.24	November	5,675.98	22,386.53	7,214.11	3,770.50
November	8,421.65	10,518.19	December	1,305.30	5,337.01	372.97	735.79
December	6.03	92.61	January	39,379.85	43,650.07	25,670.23	21,798.52
January	70,721.63	61,025.94	February	33,190.81	53,363.98	37,309.68	47,098.16
February	91,693.11	80,458.14	March	78,691.30	65,073.23	88,220.14	
March	79,640.86	103,148.90	April	24,930.11	36,514.38	15,613.35	
April	25,898.74	29,908.61	May	16,846.94	21,292.12	25,246.23	
May	59,813.76	26,019.65	June	129,015.93	64,462.43	68,319.25	-
Total	759,981.49	939,337.63		641,106.81	700,761.03	535,093.50	417,911.86

Sales Tax Revenue

	<u>FY10</u>	<u>FY11</u>	<u>FY12</u>	<u>FY13</u>	<u>FY14</u>	<u>FY15</u>	<u>FY16</u>
June	73,942.45	96,304.83	July	101,206.98	82,934.73	104,201.30	88,780.27
July	76,586.24	98,121.00	August	76,571.79	73,136.15	88,102.34	92,491.15
August	59,031.08	77,436.07	September	194,900.07	75,647.72	116,436.20	95,569.47
September	66,560.56	89,882.29	October	85,720.47	69,251.83	81,510.79	71,821.64
October	55,806.67	93,787.49	November	90,575.50	46,816.20	43,535.59	35,841.10
November	37,712.73	34,431.36	December	44,723.29	52,116.25	44,980.97	48,357.80
December	46,246.45	59,315.91	January	62,428.48	80,977.40	66,575.33	60,942.89
January	51,438.40	72,690.48	February	57,547.22	84,035.36	69,895.86	60,702.43
February	66,045.08	68,392.21	March	75,307.36	126,325.95	105,731.28	
March	109,345.24	83,181.02	April	65,117.67	86,407.71	58,562.79	
April	59,248.18	72,659.25	May	58,775.64	70,189.92	52,976.00	
May	50,158.53	56,084.05	June	80,381.46	98,758.26	96,824.06	-
Total	752,121.61	902,285.96		993,255.93	946,597.48	929,332.51	554,506.75
					TDX Fines	(150,000.00)	
						779,332.51	

City of Sand Point
Bank Balance

Date

		Balance	
		Date	
Bank	Account Number	End of FEBRUARY	4/8/2016
Key Bank	50-20-500-0025757	1,996,781.55	1,897,426.00
Wells Fargo - General	4121344139	91,916.62	136,184.22
Wells Fargo - Bingo Fund	4121344147	239,429.32	253,291.66
Wells Fargo - Silver Salmon Fund	4121344154	26,131.34	26,131.34
AlaskaUsa Federal Credit Union CD	1957756	401,946.58	402,252.11

CITY OF SAND POINT
***Expenditure Guideline-No Enc Sum©**

04/04/16 10:15 AM

Page 1

Current Period: FEBRUARY 15-16

	15-16 YTD Budget	15-16 YTD Amt	FEBRUARY MTD Amt	15-16 YTD Balance	% of YTD
GENERAL FUND					
LEGISLATIVE	\$138,000.00	\$94,660.57	\$5,223.24	\$43,339.43	68.59%
ADMINISTRATION	\$995,754.00	\$773,304.32	\$55,887.58	\$222,449.68	77.66%
PARKS AND RECREATION	\$28,000.00	\$17,344.37	\$1,866.52	\$10,655.63	61.94%
ANIMAL CONTROL	\$0.00	\$0.00	\$0.00	\$0.00	0.00%
PUBLIC SAFETY	\$602,750.00	\$346,326.34	\$40,451.25	\$256,423.66	57.46%
PUBLIC WORKS	\$646,910.00	\$392,049.79	\$43,426.98	\$254,860.21	60.60%
FACILITIES	\$371,850.00	\$126,024.98	\$13,920.01	\$245,825.02	33.89%
<i>Total GENERAL FUND</i>	\$2,783,264.00	\$1,749,710.37	\$160,775.58	\$1,033,553.63	62.87%
BINGO FUND					
ADMINISTRATION	\$474,100.00	\$472,844.70	\$31,361.74	\$1,255.30	99.74%
<i>Total BINGO FUND</i>	\$474,100.00	\$472,844.70	\$31,361.74	\$1,255.30	99.74%
SILVER SALMON DERBY					
FIRE	\$19,250.00	\$17,431.28	\$16,026.60	\$1,818.72	90.55%
OTHER	\$0.00	\$0.00	\$0.00	\$0.00	0.00%
<i>Total SILVER SALMON DERBY</i>	\$19,250.00	\$17,431.28	\$16,026.60	\$1,818.72	90.55%
CLINIC OPERATIONS/MAINTENANCE					
ADMINISTRATION	\$32,777.00	\$0.00	\$0.00	\$32,777.00	0.00%
<i>Total CLINIC OPERATIONS/MAINTENANCE</i>	\$32,777.00	\$0.00	\$0.00	\$32,777.00	0.00%
WATER/SEWER OPERATIONS					
WATER/SEWER	\$284,600.00	\$174,784.14	\$34,170.48	\$109,815.86	61.41%
<i>Total WATER/SEWER OPERATIONS</i>	\$284,600.00	\$174,784.14	\$34,170.48	\$109,815.86	61.41%
HARBOR/PORT OPERATIONS					
HARBOR	\$557,487.00	\$398,397.43	\$55,168.14	\$159,089.57	71.46%
<i>Total HARBOR/PORT OPERATIONS</i>	\$557,487.00	\$398,397.43	\$55,168.14	\$159,089.57	71.46%
REFUSE COLLECTION					
PUBLIC WORKS	\$156,094.00	\$93,620.87	\$9,271.07	\$62,473.13	59.98%
<i>Total REFUSE COLLECTION</i>	\$156,094.00	\$93,620.87	\$9,271.07	\$62,473.13	59.98%
SCHOOL LOOP ROAD & PAVING PROJ					
ADMINISTRATION	\$0.00	\$0.00	\$0.00	\$0.00	0.00%
<i>Total SCHOOL LOOP ROAD & PAVING PROJ</i>	\$0.00	\$0.00	\$0.00	\$0.00	0.00%
HARBOR CONSTRUCTION					
HARBOR	\$0.00	\$0.00	\$0.00	\$0.00	0.00%
<i>Total HARBOR CONSTRUCTION</i>	\$0.00	\$0.00	\$0.00	\$0.00	0.00%
Report Total	\$4,307,572.00	\$2,906,788.79	\$306,773.61	\$1,400,783.21	67.48%

CITY OF SAND POINT
***Revenue Guideline-Alt Code©**

04/04/16 10:13 AM

Page 1

Current Period: FEBRUARY 15-16

		15-16	15-16	FEBRUARY	15-16	% of
		YTD Budget	YTD Amt	MTD Amt	YTD Balance	YTD
GENERAL FUND						
Active	R 01-024 INTEREST INCOME	\$0.00	\$1,813.58	\$533.72	-\$1,813.58	0.00%
Active	R 01-200 INTEREST/RESTRICTED	\$2,000.00	\$457.07	\$0.00	\$1,542.93	22.85%
Active	R 01-201 INTEREST INCOME	\$0.00	\$18.00	\$0.00	-\$18.00	0.00%
Active	R 01-202 FINES AND PENALTYS	\$500.00	\$36.44	\$0.00	\$463.56	7.29%
Active	R 01-203 OTHER REVENUE	\$45,000.00	\$40,255.59	\$10,058.89	\$4,744.41	89.46%
Active	R 01-205 4% SALES TAX	\$850,000.00	\$586,395.72	\$60,973.75	\$263,604.28	68.99%
Active	R 01-213 RAW FISH TAX	\$600,000.00	\$439,132.95	\$21,798.52	\$160,867.05	73.19%
Active	R 01-214 FINE-LATE SALES TAX	\$1,000.00	\$1,574.66	\$0.00	-\$574.66	157.47%
Active	R 01-217 7% B & B Tax	\$16,500.00	\$8,135.40	\$1,191.56	\$8,364.60	49.31%
Active	R 01-225 PAYMENT IN LIEU OF TAX	\$150,000.00	\$0.00	\$0.00	\$150,000.00	0.00%
Active	R 01-226 EVENT COSTS	\$4,500.00	\$0.00	\$0.00	\$4,500.00	0.00%
Active	R 01-229 EASTER EGG HUNT	\$0.00	\$767.00	\$100.00	-\$767.00	0.00%
Active	R 01-230 DONATIONS	\$0.00	\$3,190.00	\$0.00	-\$3,190.00	0.00%
Active	R 01-231 INSURANCE REFUND	\$0.00	\$0.00	\$0.00	\$0.00	0.00%
Active	R 01-232 EMS FUND	\$0.00	\$200.00	\$0.00	-\$200.00	0.00%
Active	R 01-233 BUSINESS LIC. FEE	\$2,500.00	\$3,950.00	\$3,600.00	-\$1,450.00	158.00%
Active	R 01-234 SB 46 PERS RELIEF	\$0.00	\$0.00	\$0.00	\$0.00	0.00%
Active	R 01-235 TRANSFER IN	\$0.00	\$0.00	\$0.00	\$0.00	0.00%
Active	R 01-236 SAND POINT SWEATSHIR	\$0.00	\$0.00	\$0.00	\$0.00	0.00%
Active	R 01-238 ANCHORAGE OFFICE	\$20,000.00	\$0.00	\$0.00	\$20,000.00	0.00%
Active	R 01-240 GRANT REVENUE RASMU	\$0.00	\$0.00	\$0.00	\$0.00	0.00%
Active	R 01-241 GRANT REVENUE APEI	\$0.00	\$0.00	\$0.00	\$0.00	0.00%
Active	R 01-242 ROAD MAINTENANCE REV	\$0.00	\$0.00	\$0.00	\$0.00	0.00%
Active	R 01-250 STATE REVENUE SHARIN	\$138,000.00	\$134,653.00	\$0.00	\$3,347.00	97.57%
Active	R 01-256 REVENUE--STATE OF ALA	\$7,500.00	\$0.00	\$0.00	\$7,500.00	0.00%
Active	R 01-260 STATE BUSINESS LICENS	\$4,600.00	\$0.00	\$0.00	\$4,600.00	0.00%
Active	R 01-265 STATE PROCESSORS TAX	\$35,000.00	\$0.00	\$0.00	\$35,000.00	0.00%
Active	R 01-266 EXT FISH TAX SHARING	\$250,000.00	\$37,902.60	\$0.00	\$212,097.40	15.16%
Active	R 01-285 EQUIPMENT RENTAL	\$15,000.00	\$9,073.00	\$0.00	\$5,927.00	60.49%
Active	R 01-291 BUILDING RENTALS	\$135,000.00	\$91,068.81	\$2,893.50	\$43,931.19	67.46%
Active	R 01-293 LIBRARY GRANT	\$6,650.00	\$0.00	\$0.00	\$6,650.00	0.00%
Active	R 01-297 POLICE MISC REVENUE	\$35,000.00	\$1,898.65	\$275.00	\$33,101.35	5.42%
Active	R 01-298 EMS MISC REVENUE	\$500.00	\$0.00	\$0.00	\$500.00	0.00%
Active	R 01-299 GAIN/LOSS DISPOSITION	\$0.00	\$0.00	\$0.00	\$0.00	0.00%
	Total	\$2,319,250.00	\$1,360,522.47	\$101,424.94	\$958,727.53	58.66%
	Total GENERAL FUND	\$2,319,250.00	\$1,360,522.47	\$101,424.94	\$958,727.53	58.66%
BINGO FUND						
Active	R 02-051 TRANSFER OUT	\$0.00	\$0.00	\$0.00	\$0.00	0.00%
Active	R 02-052 TRANSFER TO OTHER FU	\$0.00	\$0.00	\$0.00	\$0.00	0.00%
Active	R 02-202 FINES AND PENALTYS	\$0.00	\$3,814.00	\$3,814.00	-\$3,814.00	0.00%
Active	R 02-234 SB 46 PERS RELIEF	\$0.00	\$0.00	\$0.00	\$0.00	0.00%
Active	R 02-235 TRANSFER IN	\$0.00	\$0.00	\$0.00	\$0.00	0.00%
Active	R 02-294 BINGO REVENUE	\$45,000.00	\$36,845.00	\$2,622.00	\$8,155.00	81.88%
Active	R 02-295 PULL TAB REVENUE	\$470,000.00	\$509,163.20	\$30,441.00	-\$39,163.20	108.33%
Active	R 02-863 CONCESSIONS	\$300.00	\$0.00	\$0.00	\$300.00	0.00%
	Total	\$515,300.00	\$549,822.20	\$36,877.00	-\$34,522.20	106.70%
	Total BINGO FUND	\$515,300.00	\$549,822.20	\$36,877.00	-\$34,522.20	106.70%
SILVER SALMON DERBY						

CITY OF SAND POINT
***Revenue Guideline-Alt Code©**

04/04/16 10:13 AM

Page 2

Current Period: FEBRUARY 15-16

		15-16	15-16	FEBRUARY	15-16	% of
		YTD Budget	YTD Amt	MTD Amt	YTD Balance	YTD
Active	R 03-004 SILVER SALMON DERBY	\$18,250.00	\$24,014.12	\$0.00	-\$5,764.12	131.58%
Active	R 03-230 DONATIONS	\$1,000.00	\$0.00	\$0.00	\$1,000.00	0.00%
Active	R 03-292 SILVER SALMON DERBY	\$0.00	\$0.00	\$0.00	\$0.00	0.00%
	Total	\$19,250.00	\$24,014.12	\$0.00	-\$4,764.12	124.75%
	Total SILVER SALMON DERBY	\$19,250.00	\$24,014.12	\$0.00	-\$4,764.12	124.75%
CLINIC OPERATIONS/MAINTENANCE						
Active	R 10-257 REVENUE--FEDERAL GOV	\$32,777.00	\$21,851.12	\$2,731.39	\$10,925.88	66.67%
	Total	\$32,777.00	\$21,851.12	\$2,731.39	\$10,925.88	66.67%
	Total CLINIC OPERATIONS/MAINTENANCE	\$32,777.00	\$21,851.12	\$2,731.39	\$10,925.88	66.67%
WATER/SEWER OPERATIONS						
Active	R 61-052 TRANSFER TO OTHER FU	\$0.00	\$0.00	\$0.00	\$0.00	0.00%
Active	R 61-202 FINES AND PENALTYS	\$2,000.00	\$2,437.03	\$8.18	-\$437.03	121.85%
Active	R 61-203 OTHER REVENUE	\$0.00	\$0.00	\$0.00	\$0.00	0.00%
Active	R 61-206 WATER/SEWER REVENUE	\$180,000.00	\$136,218.12	\$8,558.05	\$43,781.88	75.68%
Active	R 61-234 SB 46 PERS RELIEF	\$0.00	\$0.00	\$0.00	\$0.00	0.00%
Active	R 61-235 TRANSFER IN	\$0.00	\$0.00	\$0.00	\$0.00	0.00%
	Total	\$182,000.00	\$138,655.15	\$8,566.23	\$43,344.85	76.18%
	Total WATER/SEWER OPERATIONS	\$182,000.00	\$138,655.15	\$8,566.23	\$43,344.85	76.18%
HARBOR/PORT OPERATIONS						
Active	R 62-201 INTEREST INCOME	\$4,000.00	\$3,089.01	\$342.66	\$910.99	77.23%
Active	R 62-203 OTHER REVENUE	\$0.00	\$5,700.00	\$0.00	-\$5,700.00	0.00%
Active	R 62-210 HARBOR/MOORAGE	\$200,000.00	\$164,291.40	\$7,154.85	\$35,708.60	82.15%
Active	R 62-211 HARBOR/TRAVELLIFT	\$90,000.00	\$61,932.71	\$4,905.08	\$28,067.29	68.81%
Active	R 62-212 BOAT HARBOR/RENTS	\$100,000.00	\$60,725.60	\$590.70	\$39,274.40	60.73%
Active	R 62-215 HARBOR/WHARFAGE	\$65,000.00	\$18,459.50	\$1,841.55	\$46,540.50	28.40%
Active	R 62-219 HARBOR ELEC SERVICE F	\$8,000.00	\$5,029.07	\$257.98	\$2,970.93	62.86%
Active	R 62-220 HARBOR/ELEC DEPOSIT	\$2,500.00	\$614.65	\$0.00	\$1,885.35	24.59%
Active	R 62-221 HARBOR/VAN STORAGE	\$18,000.00	\$17,718.58	\$0.00	\$281.42	98.44%
Active	R 62-222 HARBOR/STALL ELECTRIC	\$35,000.00	\$26,058.13	\$2,053.21	\$8,941.87	74.45%
Active	R 62-223 HARBOR/ELECTRICITY	\$4,000.00	\$743.39	\$35.73	\$3,256.61	18.58%
Active	R 62-224 GEARSHED LOCKER REN	\$13,000.00	\$13,985.40	\$600.00	-\$985.40	107.58%
Active	R 62-234 SB 46 PERS RELIEF	\$0.00	\$0.00	\$0.00	\$0.00	0.00%
Active	R 62-237 HARBOR STORAGE	\$3,200.00	\$3,452.12	\$352.80	-\$252.12	107.88%
Active	R 62-285 EQUIPMENT RENTAL	\$25,000.00	\$24,648.77	\$314.81	\$351.23	98.60%
Active	R 62-299 GAIN/LOSS DISPOSITION	\$0.00	\$0.00	\$0.00	\$0.00	0.00%
	Total	\$567,700.00	\$406,448.33	\$18,449.37	\$161,251.67	71.60%
	Total HARBOR/PORT OPERATIONS	\$567,700.00	\$406,448.33	\$18,449.37	\$161,251.67	71.60%
REFUSE COLLECTION						
Active	R 65-052 TRANSFER TO OTHER FU	\$0.00	\$0.00	\$0.00	\$0.00	0.00%
Active	R 65-202 FINES AND PENALTYS	\$1,200.00	\$1,483.26	\$124.54	-\$283.26	123.61%
Active	R 65-204 REFUSE COLLECTION	\$140,000.00	\$101,487.41	\$7,471.39	\$38,512.59	72.49%
Active	R 65-234 SB 46 PERS RELIEF	\$0.00	\$0.00	\$0.00	\$0.00	0.00%
Active	R 65-235 TRANSFER IN	\$0.00	\$0.00	\$0.00	\$0.00	0.00%
	Total	\$141,200.00	\$102,970.67	\$7,595.93	\$38,229.33	72.93%
	Total REFUSE COLLECTION	\$141,200.00	\$102,970.67	\$7,595.93	\$38,229.33	72.93%
SCHOOL LOOP ROAD & PAVING PROJ						

CITY OF SAND POINT
***Revenue Guideline-Alt Code©**

04/04/16 10:13 AM

Page 3

Current Period: FEBRUARY 15-16

		15-16	15-16	FEBRUARY	15-16	% of
		YTD Budget	YTD Amt	MTD Amt	YTD Balance	YTD
Active	R 70-256 REVENUE--STATE OF ALA	\$0.00	\$0.00	\$0.00	\$0.00	0.00%
Active	R 70-262 STATE OF ALASKA/SAND	\$0.00	\$0.00	\$0.00	\$0.00	0.00%
	Total	\$0.00	\$0.00	\$0.00	\$0.00	0.00%
Total SCHOOL LOOP ROAD & PAVING PROJ		\$0.00	\$0.00	\$0.00	\$0.00	0.00%
HARBOR CONSTRUCTION						
Active	R 79-256 REVENUE--STATE OF ALA	\$0.00	\$0.00	\$0.00	\$0.00	0.00%
Active	R 79-258 REVENUE--ALEUTIANS EA	\$0.00	\$0.00	\$0.00	\$0.00	0.00%
	Total	\$0.00	\$0.00	\$0.00	\$0.00	0.00%
Total HARBOR CONSTRUCTION		\$0.00	\$0.00	\$0.00	\$0.00	0.00%
Report Total		\$3,777,477.00	\$2,604,284.06	\$175,644.86	\$1,173,192.94	68.94%

CITY OF SAND POINT

***Fund Summary -
Budget to Actual©**

FEBRUARY 15-16

	15-16 YTD Budget	FEBRUARY MTD Amount	15-16 YTD Amount	15-16 YTD Balance	15-16 % YTD Budget
FUND 01 GENERAL FUND					
Revenue	\$2,319,250.00	\$101,424.94	\$1,360,522.47	\$958,727.53	58.66%
Expenditure	\$2,783,264.00	\$160,775.58	\$1,749,710.37	\$1,033,553.63	62.87%
		<u>-\$59,350.64</u>	<u>-\$389,187.90</u>		
FUND 02 BINGO FUND					
Revenue	\$515,300.00	\$36,877.00	\$549,822.20	-\$34,522.20	106.70%
Expenditure	\$474,100.00	\$31,361.74	\$472,844.70	\$1,255.30	99.74%
		<u>\$5,515.26</u>	<u>\$76,977.50</u>		
FUND 03 SILVER SALMON DERBY					
Revenue	\$19,250.00	\$0.00	\$24,014.12	-\$4,764.12	124.75%
Expenditure	\$19,250.00	\$16,026.60	\$17,431.28	\$1,818.72	90.55%
		<u>-\$16,026.60</u>	<u>\$6,582.84</u>		
FUND 10 CLINIC OPERATIONS/MAINTENANCE					
Revenue	\$32,777.00	\$2,731.39	\$21,851.12	\$10,925.88	66.67%
Expenditure	\$32,777.00	\$0.00	\$0.00	\$32,777.00	0.00%
		<u>\$2,731.39</u>	<u>\$21,851.12</u>		
FUND 61 WATER/SEWER OPERATIONS					
Revenue	\$182,000.00	\$8,566.23	\$138,655.15	\$43,344.85	76.18%
Expenditure	\$284,600.00	\$34,170.48	\$174,784.14	\$109,815.86	61.41%
		<u>-\$25,604.25</u>	<u>-\$36,128.99</u>		
FUND 62 HARBOR/PORT OPERATIONS					
Revenue	\$567,700.00	\$18,449.37	\$406,448.33	\$161,251.67	71.60%
Expenditure	\$557,487.00	\$55,168.14	\$398,397.43	\$159,089.57	71.46%
		<u>-\$36,718.77</u>	<u>\$8,050.90</u>		
FUND 65 REFUSE COLLECTION					
Revenue	\$141,200.00	\$7,595.93	\$102,970.67	\$38,229.33	72.93%
Expenditure	\$156,094.00	\$9,271.07	\$93,620.87	\$62,473.13	59.98%
		<u>-\$1,675.14</u>	<u>\$9,349.80</u>		
FUND 70 SCHOOL LOOP ROAD & PAVING PROJ					
Revenue	\$0.00	\$0.00	\$0.00	\$0.00	0.00%
Expenditure	\$0.00	\$0.00	\$0.00	\$0.00	0.00%
		<u>\$0.00</u>	<u>\$0.00</u>		
FUND 79 HARBOR CONSTRUCTION					
Revenue	\$0.00	\$0.00	\$0.00	\$0.00	0.00%
Expenditure	\$0.00	\$0.00	\$0.00	\$0.00	0.00%
		<u>\$0.00</u>	<u>\$0.00</u>		
Report Total		<u>-\$131,128.75</u>	<u>-\$302,504.73</u>		

TO: Mayor Gardner
City Council Members

FROM: Andy Varner
City Administrator

DATE: April 6, 2016

SUBJ: Monthly Report for April 2016

Here are a few issues and items of note we've been working on since the last report:

DOCK REPLACEMENT

- PND and DOT were out for a site visit a couple weeks ago and met with various City officials. We are starting weekly project meetings. The 20% design and cost estimate is included in the FYI. Here is their report from the site visit:

The site visit went well. I believe we have consensus that construction of a new dock adjacent to the existing is the preferred alternative. The existing dock, while along in its service life, is still in relatively good shape and does not have any significant deterioration or documented load capacity limitations. I think leaving it is the prudent option.

As for the schedule, we did observe the presence of stellar sea lions and heard anecdotally that marine mammals frequent the area often, especially during peak times of the year. As such, we will conduct observations over the next several months to quantify this risk to the project, and if needed, will pursue an incidental harassment permit, which will likely effect the delivery of the project and could delay construction by one season. We are uncertain at this point, but want to be forthright regarding this potential delay. We are also looking at potentially modifying the location of the dock by translating the new structure closer to the existing dock. We have a couple drawings in development to show the potential relocated alternatives.

LEGISLATURE

- As you might be aware, the Legislature is looking at shifting more costs onto local communities as a way for them to avoid proposing any sort of broad based taxes at the state level. By passing on more costs to local governments through increased PERS and TRS contributions, eliminating revenue sharing, and taking away rural airport funding, lawmakers can shrink their budgets by essentially forcing local municipalities to raise their own taxes and fees to make up for the shortfall. It is a short-sighted way to balance Alaska's budget and AML and all of our communities have been vocal about that. *(looks like they are dropping the PERS increase for now, but I expect other approaches...)*

ENERGY

- I applied for a technical assistance grant with Dept of Energy/Alaska Energy Authority called the *Rural Alaska Competition for Energy Efficiency*. Basically, if awarded they will offer up a group of engineers and energy specialists at our disposal to help us form and carry out a strategy for making Sand Point more energy efficient and self-sufficient. TDX is on board with our application, as it essentially took many elements of their high

penetration wind vision for the community. The winners of the grant will be announced April 26.

- John Lyons of TDX is out visiting this week to look into the wind/heat project for the school and clinic, and also investigate new streetlights in town. There are several details to work out for the clinic project, including electric boiler maintenance and the new electricity rate for the heating kWh's.

GCI/CLINIC

- GCI's team was in Sand Point for a couple weeks to perform the fiber installation between the earth station and clinic. After a few little snags that project is wrapping up.

OFFICE COPIER

- Kudos to the Mayor for standing his ground on our office copier. We got the current lease voided on the machine (half way through), didn't pay the last few months, and have a free year of service and maintenance included.

BUDGET

- We'll have first reading of the budget at the May meeting.

PERSONAL LEAVE

- I'm taking some personal leave to go see family down south April 18-29.



JOHN H. LUCKING, JR
CHIEF OF POLICE

SAND POINT DEPARTMENT of PUBLIC SAFETY

Post Office Box 423
Sand Point, Alaska 99661
EMAIL: sppd@arctic.net



TEL: (907)383-3700
FAX:(907)383-5496

MEMORANDUM

To: Honorable Glen Gardner, Mayor, City of Sand Point
Mr. Andy Varner, City Administrator, City of Sand Point
Mr. Danny Cumberlidge, City Councilperson, City of Sand Point
Mr. Allan Starnes, City Councilperson, City of Sand Point
Ms. Shirley Brown, City Councilperson, City of Sand Point
Mr. Jack Foster Jr, City Councilperson, City of Sand Point
Ms. Marita Gundersen, City Councilperson, City of Sand Point
Mr. Emil Mobeck, City Councilperson, City of Sand Point

From: John H. Lucking, Jr., Public Safety Manager

Date: April 6th, 2016

Ref: Department of Public Safety's Monthly Report for March 2016

Police Department

Public Safety Manager

- John H. Lucking, Jr.

Police Officers

- Efen Thao, Police Officer (Community Oriented Policing Grant Position)
- Michael Chiesa, Sergeant
- Open Officer Position, (currently recruiting)
- Open Officer Position, (currently recruiting)

- Eric Tupper resigned his police officer position in March of 2016 after providing the City with two years of quality police service. Officer Tupper's contributions to the Department and the community are already missed. Recruitment for his replacement is ongoing.

Administrative Assistant

- Denise Mobeck/Day Dispatcher

Dispatchers

- Alfred 'Jesse' Pesterkoff, 911 Dispatcher
- Christine Nielsen, 911 Dispatcher

Police Division Activity

MARCH 2016

4 cases were generated in March

- 2 Arrest Warrants

- 1 Agency assist

- 1 Harassment/Stalking case

There were 2 persons jailed

- both on arrest warrants

There were 30 calls to 911 in March

- 12 MOC (Medic on Call) requests

- 2 ambulance requests - same incident

- 7 hang up or mis-dial calls

- 1 person lost and in need of assistance

- 1 Civil issue

- 2 drug information calls

- 1 Bar fight

- 4 Drunken disturbances

Officer Calls for Service

- 1 trespass warning

- 1 for Information on a wanted person

- Multiple welfare checks

- Request for assistance with an ambulance patient

- 1 call to remove a subject from the tavern

Other Officer Activity

- Abandoned vehicle checks

- Courtesy transports

- Numerous bar checks

- Reckless driving contacts

- Paper services

- Prisoner transports to airport

- Warrant service attempts

- Animal control activity to include collecting & impounding dogs

6 traffic stops

- 1 DUI investigation

- 2 warnings for equipment violations

- 1 DWOL (Driving Without a License) and equipment violations on a 4-wheeler

- 1 failure to stop at stop sign

- 1 warning for excessive speed

EMS Division

Chief of EMS Division:

- Denise Mobeck, EMS Coordinator

EMS Activity:

Rescue1 transported 1 patient to clinic

Upcoming Training:

Eastern Aleutian Tribes/EMS (Emergency Medical Services) is holding an ETT (Emergency Trauma Technician) certification class April 23- May 8. Anyone interested in becoming ETT certified and being a part of the EMS team is encouraged to call Denise Mobeck at 383-3700.

Fire Division

Chief of Fire Division:

- Vacant, administrative duties being fulfilled by DPS Manager and supported by DPS and DPW personnel.

Activity:

- Recruitment efforts continue as the department seeks to fill the vacant fire chief position. Discussion is continuing about the opportunity to combine the Fire Chief position with an airport safety position if airport security levels are changed.
- All monthly incident reports were filed with the State Fire Marshal's Office meeting obligations and maintaining agency certification.

March 2016 Public Works Report

Shop

- Welded on the trash truck
- Hauled back 20ft flat for trident
- Hauled rock for fishing game and GCI 80yds
- Finished transmission on cop car
- Dug grave
- Snow removal and sand roads
- Fueled buildings
- Assist harbor with freight boats
- Rebuilt front end and breaks on Gehl
- Replaced battery on Gehl
- Hauled gear for GCI
- Hauled cars to landfill

Landfill

- Been Busy

Recycling

- Recycling center is running fine

Water & Sewer

W&S March 2016

1. Replaced shut off valve on ADF&G water service.
2. Ran new water line to side of new ADF&G building
3. Completed Revised Total Coliform work for ADEC. Population increased to 1094 when transients and non-transients were included. We now have to test for Coliform Bacteria twice a month. ADEC approved new sampling plan. We need to work with Marine View B&B and Anchor Inn Motel to identify daily average occupants to revise the population count for the ADEC Drinking Water Division.
4. Helping Trident identify problem with their sewer line piping from the Trident Store. We jetted the line to get to drain. We found blockage in pipe and looked at it with our TV camera. Enjoyed working with the Trident maintenance crew.
5. Looks like the GCI fiber optic cable run has missed our water and sewer pipes.
6. Our W&S new hire is working out well.
7. Added extra hose to make vacuuming Russian Town sewer plant easier and we really have started to make progress in remove floating solids that include an incredible amount of grease.

Robert E. Galovin Small Boat Harbor 4/08/16

Hauled containers to fish and game building site, the Gehl broke.

Greased hoist chains on Travelift, aired tires, 150 lbs. each

Turned fresh water supply on in harbor.

Lights on A-float walk way have finally been repaired.

Hauling launching and moving boats on a regular basis.

Spent some time with visitors from DOT and PND. The folks were here taking a peek at the dock and causeway in preparation for the new dock to be built for the ferry.

Crew removed vehicle barriers from in front of boats.

Hauled Gehl to public works for major brakes repairs (Thank you, Public Works).

Did some electrical repair work on fire boat (Rainmaker) air pump, working fine.

Crew still building boat blocking.

Crew making dump runs as needed.

Crew up to speed (all accounted for so far).

That's all I have for now.

Richard Kochuten Sr.
Harbor Master

**STUDENT
REPRESENTATIVE**

HEARINGS, ORDINANCES AND RESOLUTIONS

**RESOLUTION 16-02:
APPROVING ANNEXATION
PETITION SUBMISSION TO
LBC**

Memo

To: Mayor Gardner
From: Andy Varner, Administrator
cc: City Council
Date: April 5, 2016
Re: Annexation

We held our public hearing on the annexation petition last month, and I incorporated those meeting minutes and comments into the document. Now the next step in the process is to adopt a Council resolution to formally authorize submitting the petition to the Local Boundary Commission.

Once it reaches the LBC they will do a technical review and let me know how things look. The clock officially starts on the whole process once I submit the file, and then there are more opportunities for public review, analysis, etc. As a reminder, we are trying to line up approval of the annexation petition this year so that it can be before the Legislature next January, since they give the official seal of approval.

If everything is in order and the Legislature does not disapprove the petition, the proposed boundary change becomes effective 45 days after submission. *In essence, the change could be in place by the middle of February, 2017.*

City of Sand Point



RESOLUTION 16-02

A RESOLUTION OF THE SAND POINT CITY COUNCIL AUTHORIZING THE CITY ADMINISTRATOR TO SUBMIT A PETITION TO THE ALASKA LOCAL BOUNDARY COMMISSION FOR ANNEXATION OF POPOF ISLAND AND ITS SURROUNDING WATERS, APPROXIMATELY 245 SQUARE MILES, TO THE CITY OF SAND POINT BY THE LEGISLATIVE REVIEW METHOD

WHEREAS, the City of Sand Point is a First Class City and is a political subdivision of the State of Alaska; and

WHEREAS, the City wishes to incorporate certain community assets into municipal boundaries, such as the landfill, Red Cove, fishing grounds, and popular hiking and hunting trails; and

WHEREAS, by extending the municipal boundaries to include the remainder of Popof Island and its surrounding waters, the City is preparing to address anticipated economic development and anticipated/existing health and safety concerns; and

WHEREAS, the City's boundaries were last extended and approved by the Local Boundary Commission through annexation in 1994; and

WHEREAS, the community and the region's economy have undergone many changes in that time to warrant further annexation in order to help the citizens, businesses, and Tribes of Sand Point; and

WHEREAS, the legal boundary description of the territory proposed for annexation is attached as "Attachment A," and the territory is shown on the attached map as "Attachment B," both of which are incorporated herein by reference; and

WHEREAS, the City Administrator is designated as the representative of the City for all matters relating to the annexation petition.

NOW, THEREFORE BE IT RESOLVED, that the Sand Point City Council authorizes the City Administrator to submit a petition to the Alaska Local Boundary Commission using the Legislative Review Method, and that this resolution shall become effective immediately.

PASSED AND APPROVED this 12th day of April, 2016.

CITY OF SAND POINT

Glen Gardner Jr., Mayor

ATTEST:

Shannon Sommer, City Clerk

OLD BUSINESS

ATV CODE OF ORDINANCES

Alaska

Minimum Age Requirement: Children on certain public lands must be 14 years old to operate an ATV unless they are supervised by an adult.

Safety Education Certification Requirement: Children under 18 operating ATVs on public lands without adult supervision must have a safety certificate

Washington

Minimum Age Requirement: To cross a highway or to drive an ATV on a highway, operators must be 13 years old. On specified lands, riders that are not at least 13 years old must be supervised by an individual who is at least 18 years old and holds a valid driver's license.

Helmet and/or Eye Protection Requirement: All riders must wear an approved helmet except if the ATV is operated for an exempted activity such as agriculture.

Colorado

Minimum Age Requirement: No person under age ten may operate an ATV on any public street, road, or highway unless under the immediate supervision of an individual who holds a valid driver's license.

Vermont

Minimum Age Requirement: Riders in Vermont must be 12 years old or be supervised to operate ATVs. To cross a highway or to operate an ATV on a highway, riders must be at least 12 years old and, if they are under 16 years old, supervised by an adult. Unless they possess a safety certificate, a rider under 18 years old may operate an ATV only on his or her own property, the property of a parent or guardian, or under the supervision of a certified safety instructor

Safety Education Certification Requirement: Persons under age 18 must have a safety certificate to operate an ATV in Vermont.

Utah

Basic OHV Laws and Rules

- **Wear Your Helmet:** For riders and passengers under age 18, it's the law, but we advise everyone to wear a helmet. It can save your life. Properly worn, a helmet won't reduce vision or hearing, and helps cut out windblast. Gloves, abrasion resistant clothing, and over the ankle boots are also highly recommended
- Youth, 8-15 years of age, must take the Utah *Know Before You Go!* certification course before operating an OHV on public land
- **Protect Your Privilege - Ride only in areas designated as open to OHVs - Stay on Trails**
- Ride on the right side of the road and in single file
- Be alert to oncoming traffic, especially on blind curves or in dips and crests of hills
- It is illegal to drive an OHV while under the influence of alcohol or drugs
- A red or orange "whip flag" must be attached to OHVs when riding in sand dune areas
- Lights must be used between sunset and sunrise
- Be sure your brakes will control and stop your OHV
- Mufflers with an approved spark arrestor are required on all OHVs (snowmobiles do not require spark arrestors)

The Utah's Off-Highway Vehicle Program brochure outlines the basic responsibilities of Utah's OHV riders. The brochure covers registration, equipment, and operation requirements, safety tips, courtesy and ethics.

Montana

Laws & Regulations

All riders in Montana who are under the age of 16 and over the age of 11 are **REQUIRED** to complete an approved **ATV Safety Course**, and carry the **Montana ATV Safety Certificate** with them while riding on public roads open to full size vehicles.

Note:

In order to operate on designated roads, OHVs must be street legal (licensed). These vehicles must also be equipped with all the required "street-legal" gear, including headlights, brake lights, a working muffler, etc. Please consult state regulations for required equipment.

In order to ride on public lands in Montana, all OHVs must be registered with the state and display a current registration decal.

ATV Safety Gear Requirements

Montana State Parks, a division of Montana Fish, Wildlife and Parks strongly encourages ALL ATV riders to wear a proper helmet, eye protection, gloves and over-the-ankle boots when riding any ATV. A helmet is the single most important piece of safety equipment you can have, and wearing one while riding can save your life! All riders under the age of 18 are required by state law to wear a helmet.

Ride Safe and Legal!

Before heading out on Montana's ATV and OHV trails, please remember the following tips to ensure a safe and enjoyable ride:

- Always wear appropriate safety gear when riding.
 - Ensure your ATV is properly registered in the state.
 - Always stay on designated trails. Stay off paved roads.
 - Obtain the landowner's permission before going onto private land.
 - Know before you go - contact the landowner or land management agency to find out about open ATV trails or routes.
 - Never, ever ride an ATV while under the influence of drugs or alcohol.
-

Oregon ATV Safety Education Requirements

The state of Oregon is currently phasing in mandatory ATV safety education for all riders by the year 2014. Each year since 2009, a new age group has been required to carry the Oregon ATV Safety Education Card according to the schedule below.



As of January 1, 2012, online training is required for all operators under the age of 50. By January 1, 2014, ALL operators must complete online training to obtain an ATV safety education card.

Additional hands-on training is required for youth 15 and under. For more information on hands-on training, go to www.oregonohv.org/OPRD/ATV/.

Age Restrictions in Oregon

There is no minimum age for operating a Class I ATV. Dirt bike operators must be at least seven years old.

Youth 15 years of age and under must be supervised by an adult who can provide immediate assistance and direction. Supervising adults are required to carry an ATV Safety Education Card.



Helmet Safety Program: Snow Machines & ATV Resources

A reasonable program to for Children on Snow Machines or AK ATV Adventure Online

- Chronic Disease Prevention and Health Promotion
- All Programs
- Contacts
- Home
- Informed Alaskans - Health Maps
- News
- Publications
- Safe and Healthy Me Webinar Series
- Programs
- Behavioral Risk Factor Surveillance System (BRFSS)
- Cancer Prevention and Control
- Diabetes Prevention and Control
- Family Violence Prevention
- Heart Disease and Stroke Prevention
- Injury Prevention
 - Child Passenger Safety
 - Driver Safety
 - Fall Prevention — Workout To Go! Alaska
 - Fire-Related Injury Prevention
 - Helmet Safety
 - Poison Prevention
 - Bike-n-Walk Safely Alaska
 - Water Safety - Kids Don't Float
- Obesity Prevention and Control
- School Health
- Tobacco Prevention and Control
- Youth Risk Behavior Survey

Contact Us

Injury Prevention
Email Us
or call:(907) 754-3421

Address

3601 C Street, Suite 722
Anchorage, AK 99503

FAX

907-269-5446

- Injury Prevention Programs
- Child Passenger Safety
- Fall Prevention — Workout To Go! Alaska
- Fire-Related Injury Prevention
- Helmet Safety
- Poison Prevention
- Bike-n-Walk Safely Alaska
- Water Safety - Kids Don't Float
- Resources
- Alaska Health Education Library Project (AHELP)
- Arthritis Resources
- Center for Health Data and Statistics
- Healthy Alaskans 2020
- Healthy Alaskans 2010

- [Home](#)

- [About Us](#)

- [FAQ](#)

- [LINKS](#)

- [Privacy Policy](#)

- [CONTACT US](#)



Visit the 4-H Mall for your 4-H related ATV materials
[Visit 4-H Mall](#)

- [American National 4-H Youth Conference Center](#)
- [National Headquarters](#)
- [4-H Staff](#)
- [National Association of 4-H Specialists](#)
- [4-H Agents](#)

[Questions?](#)
[Contact Us!](#)

[Mike Kump](#)
 4-H ATV Safety Multi-State Coordinator
 (405) 657-7444

ATVs are popular among youth and adults for recreation and for utility use. They can be useful for work and fun to ride, but they can also be dangerous if the rider doesn't operate the ATV safely. Understanding the right way to safely ride the right-sized ATV for you is important before you ride. This website is a place where you can learn about ATVs, watch videos about ATVs, find out what size ATV you should ride, and play games and take quizzes to help you find out how much you know about ATV safety.



The ATV Safety Institute (ASI) offers three age specific e-learning courses to address basic ATV safety principles. Adults, teens and children learn how to apply the "golden rules" of ATV riding in an interactive setting. After taking the course, users can take an ATV safety exam and receive a certificate of completion. [Enroll Now!](#)



In a forgotten land the minions of evil have returned once again.

Ride your ATV through mysterious locations and defeat the horrible monsters to free the town from their evil grasp!

[See more games and quizzes!](#)

Videos

Brothers Kyle Massey (star of Disney's "Cory in the House") and Chris Massey (star of Nickelodeon's "Zoey 101") are longtime ATV riders! Along with their mom they bring tremendous energy and great humor to the serious topic of ATV Safety.

[View Videos](#)

News

TENNESSEE 4-H IS TEACHING YOUNG PEOPLE HOW TO RIDE ATVS SAFELY

Through a grant provided by National 4-H Council and the ATV Safety Institute, 4-H staff are becoming ASI ATV Safety instructors and are teaching the 4-hour hands-on RiderCourse.

[Check out their news video!](#)

TENNESSEE 4-H PARTNERS WITH THE MONROE CARELL JR. CHILDREN'S HOSPITAL

Tennessee 4-H Youth Development Program is partnering with the The Monroe Carell Jr. Children's Hospital at Vanderbilt to promote ATV safety.

[Read the Article](#)

[Read All ATV Safety News](#)

Resources and Documents

This website has information and fun for everyone interested in learning about ATV safety. Play the Tread-Sylvania game while learning key tips on riding safely. Additional games and quizzes are fun for younger youth. Visit the ATV Safety Institute's on-line E-Course and receive a certificate for completing the

class.

The lead provisions of the Consumer Product Safety Improvement Act (CPSIA) affecting youth model ATVs for ages 12 and under was lifted in August, 2011. Youth ATV models are available once again. Be sure that all youth 16 and under operate and ride the appropriate sized ATV. Follow the warning label on the ATV. This site provides links to State and National resource sites to find out about state and national laws, and other resources.

[View Resources](#)

"Do the Ride Thing"

IRVINE, Calif., June 1, 2012 – With the busy summer riding season upon us, the ATV Safety Institute, the Right Rider Access Fund and the Motorcycle Safety Foundation DirtBike School encourage kids to enter the "Do the Ride Thing" Video Contest. The contest, in its third year, runs June 1 to August 15, 2012 and offers 19 prizes totaling \$8,500. Students ages 6 to 18 may enter. The winning videos will be used as public service announcements (PSAs).

[Read the Article](#)

© website hosted by the Oklahoma State 4-H Program



You are not logged in. ()
English (en) v

Available Courses

Welcome to the ATV Safety Institute Online Course.

The adult course is similar in content to the teen and also includes a "Supervisors" module that includes information helpful to parents and caregivers that will be supervising younger ATV riders. If you selected a state specific course state law and regulation information will be displayed during the course. To receive a state certificate where applicable please review this (or Teen) course and practice quiz and then successfully complete the State Certification Quiz. The course is free, but there is a \$25 fee to take the State Certification Quiz.



Calendar

Support: 800.4

Sun	Mon	Tue	Wed	Thu	Fri	Sat
	1	2	3	4	5	6
7	8	9	10	11	12	13
14	15	16	17	18	19	20
21	22	23	24	25	26	27
28	29					

The Teen course is similar in content to the Adult course but does not include the "Supervisors" module. If you selected a state specific course, state law and regulation information will be displayed during the course. To receive a state certificate (where applicable) please review this (or Adult) course and practice quiz and then successfully complete the State Certification Quiz. The course is free, but there is a \$25 fee to take the State Certification Quiz.



To Parents and Supervisors:
The Child course is generally intended for youth ages 6-11 years. This course is activity based and does not include state specific information needed to complete the state certification quiz. To receive a state certificate please review the Teen (or Adult) course and practice quiz and then complete the State Certification Quiz with your child.





Login to the site

You are not logged in. ()

English (en) v

Returning Visitor

Login here using your User ID and password (Cookies must be enabled in your browser) ?

User ID [] Password [] Login

Forgotten your User ID or password?

Yes, help me log in

First Time Visitor

Welcome to the ATV Safety Institute's free ATV E-Course

The ATV Safety Institute (ASI) offers three age specific e-learning courses to address basic ATV safety principles. Adults, teens and children will learn how to apply the "golden rules" of ATV riding in an interactive setting while enjoying opening comments from Kyle Massey from the hit TV show, Cory in the House. The course includes videos, pictures, and interactive games to make it a fun and effective learning experience for all age groups. After taking the course, users can take an ATV safety exam and receive a certificate of completion.

The entire course takes approximately 2-2.5 hours to complete. You can stop at any point and your progress will be saved so that you can return and pick up right where you left off.

Simply click CREATE NEW ACCOUNT below and complete the enrollment information to gain access to the courses. It's free, fun and a great learning experience for ATV riders of all ages.

State Certification

Some states require riders to complete an approved safety course in order to operate an ATV. To receive your state certificate enroll in a state specific course, take the quiz, and upon successful completion you will be sent a certification card (fee required). There is no cost to take the course or practice quiz - you only pay a \$25 fee if you want to take the quiz to receive a state certificate.

Create new account

Barrow, AK

Chapter 8.13 SNOWMOBILES AND OFF-ROAD VEHICLES

Sections:

- 8.13.010 Negligent, reckless or vexatious operation.
- 8.13.020 Operator eligibility.
- 8.13.040 Helmets.
- 8.13.050 Required equipment.
- 8.13.060 Seating for operators and passengers.
- 8.13.070 Parental responsibility.
- 8.13.075 Owner's responsibility.
- 8.13.080 Hearing procedures.
- 8.13.090 Registration decals.
- 8.13.100 Registration fee.
- 8.13.110 Registration decals not transferable.
- 8.13.130 Definitions.
- 8.13.140 Penalty.

8.13.010 Negligent, reckless or vexatious operation.

A. No person shall operate an off-highway vehicle upon any street, roadway or alley located within city limits in a:

1. Reckless manner, as provided in AS 28.35.040(a);
2. Negligent manner, as provided in AS 28.35-.045(a), so as to endanger the safety of any person or property; or
3. Vexatious manner, as defined in Section 8.13.130 of this chapter so as to disturb the public peace in violation of Section 9.18.010.

B. Lawfully conducted snowmobile or other off-highway vehicle racing or exhibition events are not subject to the provisions of this section. (Ord. 91-11 §3(part); Ord. 88-12 §3(part))

8.13.020 Operator eligibility.

Individuals may operate an off-highway vehicle upon all streets, and roadways within the city limits without a valid automobile operator's license since the council has designated all streets and roadways as being exempted from the valid automobile operator's license requirement for off-road vehicles. (Ord. 2005-07 §2: Ord. 2000-05 §5: Ord. 95-10 §4(part): Ord. 91-11(A) §3: Ord. 91-11 §3(part): Ord. 89-11 §2(part): Ord. 88-12 §3(part))

8.13.040 Helmets.

No person may:

A. Operate an off-highway vehicle other than a snowmobile without wearing a helmet which meets the safety standards set by the United States Department of Transportation, if the person is less than eighteen years of age;

B. Operate an off-highway vehicle other than a snowmobile while transporting a passenger who is less than eighteen years of age and who is not wearing such a helmet;

C. Ride as a passenger on an off-highway vehicle other than a snowmobile without wearing such a helmet, if the person is less than eighteen years of age. (Ord. 89-11 §2(part); Ord. 88-12 §3(part))

8.13.050 Required equipment.

A. No snowmobile or other off-highway vehicle may be operated upon any street within the city unless it is equipped with:

1. All equipment, in good working order, which is required for such a vehicle by 13 AAC 04.400 through 04.420 in the weather and light conditions under which the vehicle is operated; and
2. A muffler system, in good working order, which prevents operation of the vehicle from causing a violation of Section 9.18.010.

B. This section does not authorize any person to operate any vehicle which does not comply with any other equipment requirement which is applicable to the vehicle under state or federal statute or regulation. (Ord. 89-11 §2(part); Ord. 88-12 §3(part))

8.13.060 Seating for operators and passengers.

A person operating an off-highway vehicle on any street, roadway or alley within the city limits shall ride only on a permanent seat attached to the vehicle; and shall not carry another person on the vehicle unless it is equipped with seating for each person carried. No more than two people shall ride at a time on an off-highway vehicle, except that this section does not apply to a parent carrying an infant in amaaq. (Ord. 95-10 §4(part); Ord. 91-11 §3(part))

8.13.070 Parental responsibility.

No parent or guardian may authorize or knowingly permit a child under the age of sixteen to violate any provisions of this chapter. (Ord. 95-10 §4(part); Ord. 88-12 §3(part))

8.13.075 Owner's responsibility.

The owner of a snowmobile or other off-highway vehicle may not authorize or knowingly permit another person to operate the vehicle in violation of the provisions of this chapter. (Ord. 95-10 §4(part); Ord. 89-11 §2(part))

8.13.080 Hearing procedures.

Pursuant to AS 47.10.010(b), a minor accused of a violation of this chapter shall be charged, prosecuted, and sentenced in the district court in the same manner as an adult. Subject to the provisions of AS 22.15.010 through AS 22.15.270, a person cited with a violation under this chapter shall answer the charge before the magistrate of the district court. (Ord. 89-11 §2(part); Ord. 88-12 §3(part))

8.13.090 Registration decals.

A. A person may not operate or park a snowmobile or other off-highway vehicle on any street within the city unless the vehicle has been registered by a person at least eighteen years old with the city. An application for registration shall be filed with the city of Barrow office of the Department of Motor Vehicles upon forms provided by the city and the application shall furnish the following information:

1. The name, address and age of the person registering the vehicle;
2. A description of the vehicle, including the year, make, model and serial number;
3. Proof of ownership; and

4. Such other information as the mayor may require.
- B. The registrant shall be provided a registration decal. A person may not operate or park a snowmobile or other off-highway vehicle on any street within the city unless a registration decal is affixed to the rear portion of the vehicle.
 - C. A registration decal is valid for as long as the registrant is the owner of the vehicle.
 - D. A failure to display the registration decal is a violation of this chapter and punishable pursuant to Section 8.13.140. No decal shall be obscure, hidden or damaged.
 - E. This section shall not apply to any vehicle at any time during which it:
 1. Is validly registered with the state of Alaska pursuant to AS 05.30 or other applicable state statute or regulation; and
 2. Displays numbered registration decals required by AS 05.30.040. (Ord. 2008-20 §2; Ord. 89-11 §2(part); Ord. 88-12 §3 (part))

8.13.100 Registration fee.

No registration decal shall be issued until the applicant has paid a fee of five dollars to the city. Upon good showing, the mayor shall waive this fee. (Ord. 88-12 §3(part))

8.13.110 Registration decals not transferable.

Registration decals issued under this chapter are personal to the registrant and may not be sold, loaned, traded, or otherwise transferred by the registrant. (Ord. 88-12 §3(part))

8.13.130 Definitions.

For the purposes of this chapter, the following words and phrases shall have the following meanings:

- A. "Off-highway vehicle" means an off-highway vehicle as defined by 13 AAC 40.010(30).
- B. "Operate" means to have actual control over the operation of a vehicle.
- C. "Operator" means a person who operates or is in actual control of a vehicle.
- D. "Snowmobile" means a snowmobile as defined by 13 AAC 40.010(49) or a snow vehicle as defined by AS 05.30- .120.
- E. "Street," "roadway" and "alley" each mean a street as defined by Section 1.04.010(R), and includes the full width of the street, whether or not developed or actually used for vehicular travel. Every "highway," as defined by AS 28.40.100(a)(6) (including but not limited to the "roadway" portion thereof, as defined by AS 28.40.100(a)(14)), and every "vehicular way or area," as defined by AS 28.40.100(a)(19) is a "street" for purposes of this chapter, if located within the city.
- F. "Vehicle" means a snowmobile or an off-highway vehicle.
- G. "Vexatious" means to operate a vehicle in such a manner as to cause excessive noise in violation of Section 9.18.010. Operation of a vehicle shall be presumed excessively noisy (i.e., "vexatious") in violation of Section 8.13.010, if the sound emitted exceeds 85 dBA (decibels) as measured from fifty or more feet. (Ord. 91-11 §3(part); Ord. 89-11 §2(part); Ord. 88-12 §3 (part))

8.13.140 Penalty.

A violation of any provision of this chapter shall constitute an infraction and shall be punishable by a maximum fine of three hundred dollars, except that no fine in excess of one hundred dollars shall be imposed for any violation of Sections 8.13.090 or 8.13.110. (Ord. 89-11 §2 (part); Ord. 88-12 §3(part))

The Barrow Municipal Code is current through Ordinance 04-2014, passed August 7, 2014.

Disclaimer: The City Clerk's Office has the official version of the Barrow Municipal Code. Users should contact the City Clerk's Office for ordinances passed subsequent to the ordinance cited above.

City Website: <http://www.cityofbarrow.org/>
(<http://www.cityofbarrow.org/>)
City Telephone: (907) 852-5211
Code Publishing Company
(<http://www.codepublishing.com/>)

NEW BUSINESS

None at this time.

ADJOURNMENT

FYI



P.O. Box 196613 • Anchorage, Alaska 99519 • www.alaskausa.org

STATEMENT OF ACCOUNT

ACCOUNT 1957756
 STATEMENT PERIOD
 FROM 03-01-16
 THROUGH 03-31-16
 PAGE 1

CITY OF SAND POINT, ALASKA
 PO BOX 249
 SAND POINT AK 99661-0249

ACCOUNT SUMMARY

SHARE ACCOUNTS		DIVIDENDS YEAR-TO-DATE	WITHHOLDING YEAR-TO-DATE	PREVIOUS BALANCE	NEW BALANCE
10	SHARE SAV	0.00	0.00	0.00	0.00
80	CERTIFICATE	448.84	0.00	201,298.41	201,451.42
81	CERTIFICATE	447.40	0.00	200,648.17	200,800.69
TOTAL SHARE ACCOUNTS					402,252.11

SHARE SAV - 10

Effective	Posted	TRANSACTION DESCRIPTION	AMOUNT	BALANCE	EXPANDED TRANSACTION DESCRIPTION
		PREVIOUS BALANCE		0.00	
		NEW BALANCE		0.00	
		DIVIDEND YEAR TO DATE	0.00		

CERTIFICATE - 80 (MATURITY DATE 12-11-2016) DIV RATE 0.895%

Effective	Posted	TRANSACTION DESCRIPTION	AMOUNT	BALANCE	EXPANDED TRANSACTION DESCRIPTION
		PREVIOUS BALANCE		201298.41	
03-31	03-31	DEPOSIT DIVIDEND 0.895%	153.01	201451.42	ANNUAL PERCENTAGE YIELD EARNED 0.90% FROM 03/01/16 THROUGH 03/31/16 BASED ON AVERAGE DAILY BALANCE OF 201,298.41
		NEW BALANCE		201451.42	
		DIVIDEND YEAR TO DATE	448.84		

CERTIFICATE - 81 (MATURITY DATE 04-21-2017) DIV RATE 0.895%

Effective	Posted	TRANSACTION DESCRIPTION	AMOUNT	BALANCE	EXPANDED TRANSACTION DESCRIPTION
		PREVIOUS BALANCE		200648.17	
03-31	03-31	DEPOSIT DIVIDEND 0.895%	152.52	200800.69	ANNUAL PERCENTAGE YIELD EARNED 0.90% FROM 03/01/16 THROUGH 03/31/16 BASED ON AVERAGE DAILY BALANCE OF 200,648.17
		NEW BALANCE		200800.69	
		DIVIDEND YEAR TO DATE	447.40		

END OF STATEMENT

ALASKA USA FEDERAL CREDIT UNION

PLEASE USE ALASKA USA'S ULTRABRANCH SERVICE
TO CONFIRM AUTOMATIC TRANSFERS AND DEPOSITS

alaskausa.org • (888) 258-7228 or (907) 258-7228

FOR OTHER QUESTIONS, CALL THE MEMBER SERVICE CENTER
(800) 525-9094 or (907) 563-4567 • TTY/Hearing Impaired (800) 742-7084
7 days a week • 6 a.m. – 10 p.m. Alaska time • 7 a.m. – 11 p.m. Pacific time

TO PROVIDE WRITTEN NOTICE REGARDING ERRORS OR QUESTIONS, SEND INQUIRIES TO:

Alaska USA Federal Credit Union
P.O. Box 196613
Anchorage, Alaska 99519-6613

- INCLUDE:
1. Your name and account number.
 2. The transaction involved, including the date and check number, if applicable.
 3. The dollar amount of the check, transaction, or suspected error.
 4. A detailed description of the question, error, or other problem.

- **In Case of Errors or Questions About Your Share Accounts:** Call us at the above number or write us at the above address as soon as you can if you think your statement is wrong or if you need more information about a transaction on the statement. You must notify Alaska USA of errors or other problems IN WRITING no later than sixty (60) days after the FIRST statement of account containing an error or problem is made available to you. However, if the error or problem involves more than one unauthorized signature or alteration by the same individual, you must notify Alaska USA IN WRITING no later than thirty (30) days after the FIRST statement containing the FIRST unauthorized transaction is made available to you. If you do not notify the credit union IN WRITING within these established time frames, you will have waived your right to assert any claim against Alaska USA for errors, unauthorized transactions or signatures, alterations or other problems; and Alaska USA shall not be liable for these or any related payments or charges made from or to your account.
- **In Case of Errors or Questions About Your Electronic Transfers:** Call us at the above number or write us at the above address as soon as you can if you think your statement or receipt is wrong or if you need more information about a transfer on the statement or receipt.

	Consumer Accounts	Non-Consumer (Business) Accounts
We must hear from you:	No later than sixty (60) days after the FIRST statement on which the error or problem occurred is made available to you.	No later than one (1) business day after the effective date of the transaction.

We will investigate your complaint and will correct any error promptly. If we take more than ten (10) business days to do this, we will credit your account for the amount you think is in error so that you will have the use of the money during the time it takes us to complete our investigation. (Business days are Monday through Friday, excluding Federal holidays.)

- **In Case of Errors or Questions About Your Credit Line Loan Bill and Statement:** If you think your bill and statement is wrong, or if you need more information about a transaction on your bill and statement, WRITE us on a separate sheet at the above address as soon as you can. We must hear from you no later than sixty (60) days after the FIRST bill and statement on which the error or problem appeared is made available to you. You may call us, but doing so will not preserve your rights.

You do not have to pay any amount in question while we are investigating your claim, but you are still obligated to pay the parts of your bill that are not in question. During the investigation, we cannot report you as delinquent or take any action to collect the amount in question.

IMPORTANT INFORMATION REGARDING CREDIT LINE LOAN BILL AND STATEMENT

- **Outstanding Loan Balance:** The outstanding loan balance is the unpaid loan balance at the close of each calendar day after all payments and advances for the day have been posted to the account.
- **Finance Charges:** Finance charges are calculated whenever any change in the outstanding loan balance occurs by multiplying the outstanding loan balance by the annual percentage rate (calculated as daily factor) times the number of days the loan balance was outstanding since the last computation of finance charges. Finance charges are collected upon receipt of payments.
- **Late Fees:** Loans in default seven (7) days or more will be assessed a late fee of 20% of the interest due upon receipt of payment with a minimum of five (5) cents and a maximum of \$25.00. There is no maximum late fee on loans in default three (3) payments or more.
- **Minimum Payment:**
 - Unsecured credit line loans: A minimum scheduled payment is due each billing cycle, whether or not the loan was paid ahead or the balance increased during the cycle. This minimum payment shall be \$10.00 or 3% of the outstanding balance, whichever is greater, plus any amount in excess of the authorized credit limit at the time of billing.
 - Secured credit lines loans: A minimum scheduled payment is due each billing cycle, whether or not the loan was paid ahead or the balance increased during the cycle. The minimum payment shall be \$25.00 or 1.5% of the outstanding balance, whichever is greater, plus any amount in excess of the authorized credit limit at the time of billing.
- **Prepayments:** Credit line loans may be paid in full or prepaid in any amount at any time.

City of Sand Point



April 1, 2016

Division of Community and Regional Affairs
Community Revenue Sharing Program
Attn: Danielle Lindoff
P.O. Box 110809
Juneau, Alaska 99811

RE: FY 2017 Community Revenue Sharing Application

Dear Ms. Lindoff:

Enclosed you will find our FY17 Community Revenue Sharing Application package including the Application Cover and the Budget Form. Also enclosed is a copy of our FY15 audit.

I will forward a copy of our FY17 budget once it is adopted by the Sand Point city council (scheduled for June 2016).

Please note that our FY17 population determination with DCRA recently changed, and the new number for Sand Point is **951**. That will affect our previously determined CRS; of course, so will the legislative activity in Juneau!

If I can provide any further information, please let me know.

Sincerely,

A handwritten signature in black ink, appearing to read "Andy Varner", with a long horizontal flourish extending to the right.

Andy Varner
City Administrator

Cc: Mayor Glen Gardner, Jr.
Sand Point City Council

**FY 2017
COMMUNITY REVENUE SHARING PROGRAM
APPLICATION COVER SHEET**

City of Sand Point

Name of City

3380 C St.

4.1.16

Date

907.274.7561

Mailing Address

Anchorage, AK 99503

Phone

907.274.3540

City, State, Zip Code

Andy Varner

Fax

avarner@sandpointak.org

Printed Full Name of Designated CRS Contact

Primary Contact E-Mail

"Minimum Qualifications"

	Yes	No	Not Applicable
a. Did your municipality successfully conduct its most recently scheduled local regular election?	<input checked="" type="checkbox"/>	<input type="checkbox"/>	
b. Are regular meetings of the governing body held in accordance with local code and a record of the proceedings maintained?	<input checked="" type="checkbox"/>	<input type="checkbox"/>	
c. Have your municipality's ordinances been codified?	<input checked="" type="checkbox"/>	<input type="checkbox"/>	
d. If the municipality levies and collects property taxes, has the municipality provided the Taxpayer Notice required by AS 29.45.020?	<input type="checkbox"/>	<input type="checkbox"/>	<input checked="" type="checkbox"/>

"Certification and Assurances"

The applicant certifies that to the best of my knowledge and belief, the information contained in this application is true and correct and the applicant agrees to comply with the laws and regulations which are used to administer Community Revenue Sharing Program funds.

Andy Varner, City Administrator

Mayor, Manager or Administrator
Printed Name, Title

Andy Varner

Mayor, Manager or Administrator
Signature

City of Sand Point



March 14, 2016

Fishermen's Finest of Alaska LLC
Fishermen's Finest, Inc.
ATTN: Kristian S. Uri
570 Kirkland Way
Ste. 200
Kirkland, WA 98033-6270

VIA U.S. MAIL

Re: City of Sand Point Sales Tax

Dear Fishermen's Finest,

The City of Sand Point requires buyers to pay and sellers to collect a 4% sales tax "on all sales within corporate limits of the city" (SPC 6.10.110(a)). In addition, the city levies a 2% tax on all sales of raw fish delivered directly or indirectly by a seller to a buyer within the City. (SPC 6.10.110(b)). Sales occur within the City "if any significant element of the making or performance of the sale agreement occurs within the City" (SPC 6.10.120). Under Section 6.10.130 of the city code, both the seller and the buyer are legally responsible for paying, collecting, and remitting sales tax on each taxable transaction within Sand Point.

Fishermen's Finest is a seller of raw seafood or processed seafood. Seafood is sold by Fishermen's Finest within city boundaries. Accordingly, Fishermen's Finest is legally responsible for remittance of the applicable sales tax to the City (SPC 6.10.130).

We are enclosing sales tax returns for Fishermen's Fund to complete and file. Please do so by April 14, 2016. Failure to submit a return will result in the city estimating the tax due and making a sales tax assessment as allowed by SPC 6.10.320(h).

These transactions constitute doing business in Sand Point. A city business license is required per SPC 9.10.020. Please complete and return the enclosed business license application by April 14, 2016 for all years in which Fishermen's Finest has sold seafood in Sand Point and for calendar year 2016.

I recently attended the Southwest Alaska Municipal Conference (SWAMC) annual meeting in Anchorage, where Groundfish Forum Executive Director Chris Woodley gave a presentation on the economic impacts of the Amendment 80 Fleet on coastal communities, including Sand Point. One of the benefits he noted was the amount of local taxes the fleet generates for our fish-dependent communities, so I am sure you can agree that our request falls right in line with the message that Mr. Woodley was conveying to the audience.

The Sand Point city code is available online at www.sandpointak.com/code-of-ordinances. There you will find more specific information on city sales tax and business license code. I have enclosed a 2016 business license application and a few blank sales returns. I assume the company's total sales for the previous year were more than \$100,000, so a monthly return is required for all months that business was done in Sand Point. Please contact me with any questions, and have a good day.

Sincerely,

CITY OF SAND POINT

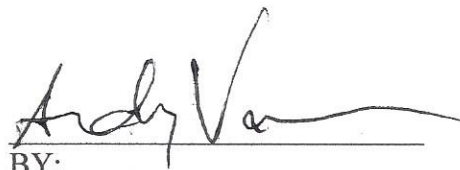
A handwritten signature in black ink, appearing to read "Andy Varner", is written over a horizontal line.

BY:

Andy Varner
City Administrator

Cc: City Attorney
Mayor Glen Gardner, Jr.
Sand Point City Council

Enclosures: 2016 Business License Application
Sales Tax Report

GENERAL NOTES:

ANY DISCREPANCIES FOUND AMONG THE DRAWINGS, SPECIFICATIONS, SITE CONDITIONS, AND THESE NOTES SHALL BE REPORTED TO THE ENGINEER AT ONCE. ANY FURTHER WORK DONE BY THE CONTRACTOR AFTER FINDING SUCH DISCREPANCIES SHALL BE DONE AT HIS OWN RISK.

APPLICABLE CODES –

ALL LOCAL CODES PLUS THE FOLLOWING SPECIFICATIONS, STANDARDS AND CODES ARE PART OF THESE GENERAL NOTES:

1. ALASKA DEPARTMENT OF TRANSPORTATION AND PUBLIC FACILITIES (ADOT&PF) STANDARD SPECIFICATIONS FOR HIGHWAY CONSTRUCTION, CURRENT EDITION
2. AASHTO LRFD BRIDGE DESIGN SPECIFICATIONS, 7TH EDITION (2014)
3. INTERNATIONAL BUILDING CODE, CURRENT EDITION
4. AWS D1.1 STRUCTURAL WELDING CODE, CURRENT EDITION
5. ACI 318, 301, 306
6. AMERICAN INSTITUTE OF STEEL CONSTRUCTION (AISC) MANUAL OF STEEL CONSTRUCTION, 14TH EDITION
7. ASTM SPECIFICATIONS
8. ASCE 61-14

IN THE EVENT THAT THERE IS A CONFLICT BETWEEN THE ABOVE REFERENCES AND THESE GENERAL NOTES THE FOLLOWING PRIORITY WILL BE FOLLOWED:

1. ALL PROJECT PERMIT REQUIREMENTS.
2. THESE GENERAL NOTES AND PLANS.
3. LOCAL CODES (& ADOT/PF SPECIFICATIONS WHERE REFERENCED).
4. THE SPECIFICATIONS, STANDARDS AND CODES LISTED ABOVE IN ORDER OF PRECEDENCE.

STRUCTURAL DESIGN CRITERIA –

DOCK DESIGN LIFE – 50 YEARS

UNIFORM LIVE LOAD – 400 PSF

DESIGN VEHICLES – AASHTO STRENGTH I

AASHTO HL93

AASHTO HS25

HYSTER CHALLENGER MODEL H700F

AASHTO STRENGTH II

115 TON TRUCK CRANE

SEISMIC –

DESIGN CLASSIFICATION: MODERATE

SITE CLASS: D (ASSUMED)

CONTINGENCY LEVEL EARTHQUAKE (CLE)

PGA = 0.272g (SITE CLASS B)

S_s = 0.616g

S_i = 0.215g

DESIGN EARTHQUAKE (DE)

PGA = 0.615g (SITE CLASS B)

S_s = 1.377g

S_i = 0.521g

BOLLARDS – 80,000 LB SAFE WORKING LOAD (SWL) IN ANY HORIZONTAL DIRECTION

DESIGN VESSELS – M/V TUSTUMENA (3,067 LONG TON DISPLACEMENT)

M/V KENNICOTT (7,683 LONG TON DISPLACEMENT)

TIDE LEVELS

ELEVATION DATUM FOR THIS PROJECT IS MEAN LOWER LOW WATER (MLLW = 0.0').

NOAA TIDAL DATUM FOR 1983-2001 TIDAL EPOCH AT SAND POINT, POPOF ISLAND ALASKA (STATION ID# 9459450)

HIGHEST OBSERVED **+11.58 FT**

MEAN HIGHER HIGH WATER (MHHW) **+7.23 FT**

MEAN HIGH WATER (MHW) **+6.52 FT**

MEAN TIDE LEVEL (MTL) **+3.93 FT**

MEAN SEA LEVEL (MSL) **+3.87 FT**

MEAN LOW WATER (MLW) **+1.33 FT**

MEAN LOWER LOW WATER (MLLW) **0.0 FT**

LOWEST OBSERVED **-3.82 FT**

SURVEY-

ALL CONSTRUCTION SURVEYS SHALL BE PERFORMED BY OR UNDER THE DIRECT SUPERVISION OF A SURVEYOR LICENSED IN THE STATE OF ALASKA.

THE CONTRACTOR SHALL VERIFY THE PROVIDED PROJECT HORIZONTAL AND VERTICAL CONTROL. THE ENGINEER SHALL BE NOTIFIED OF ANY DISCREPANCIES IN THE PROVIDED PROJECT CONTROL POINTS. SITE SPECIFIC CONTROL SHALL BE PROVIDED BY THE CONTRACTOR AS NECESSARY. THE CONTRACTOR SHALL BE RESPONSIBLE FOR MAINTAINING ALL HORIZONTAL AND VERTICAL CONTROL.

THE CONTRACTOR SHALL FURNISH AT ITS OWN EXPENSE ALL STAKES, TEMPLATES, PLATFORMS, EQUIPMENT, RANGE MARKERS, AND LABOR AS MAY BE REQUIRED TO LAY OUT THE WORK FROM THE CONTROL POINTS. IT SHALL BE THE RESPONSIBILITY OF THE CONTRACTOR TO MAINTAIN THE CONTROL POINTS UNTIL AUTHORIZED TO REMOVE THEM. IF SUCH POINTS ARE DESTROYED OR DISTURBED THEY SHALL BE REESTABLISHED BY THE CONTRACTOR AT THE CONTRACTOR'S EXPENSE.

ABBREVIATIONS

AC – ASPHALT CONCRETE
 ADOT – ALASKA DEPARTMENT OF TRANSPORTATION
 BOP – BOTTOM OF PIPE
 BP – BEGIN PROJECT
 CL – CENTERLINE
 CONN – CONNECTION
 CU – COPPER
 DIP – DUCTILE IRON PIPE
 E – EASTING
 EL – ELEVATION
 ELEV – ELEVATION
 EOP – END OF PROJECT
 EXIST – EXISTING
 F&I – FURNISH AND INSTALL
 G.V. – GATE VALVE
 HSD – HENRY SWANSON DRIVE
 HORZ – HORIZONTAL
 HTL – HIGH TIDE LEVEL
 INV – INVERT
 L – LENGTH OF CURVE
 LF – LINEAR FEET
 MAX – MAXIMUM
 MH – MAN HOLE
 MHW – MEAN HIGH WATER
 MIN – MINIMUM
 MLLW – MEAN LOWER LOW WATER
 N – NORTHING
 NIC – NOT IN CONTRACT
 NFS – NON-FROST SUSCEPTIBLE
 NTS – NOT TO SCALE
 NWT – NO WATER TABLE
 PC – POINT OF CURVATURE
 PI STA – POINT OF INFLECTION STATION
 PT – POINT OF TANGENT
 PVI STA – POINT OF VERTICAL INFLECTION STATION
 QAR – QUARRY ACCESS ROAD
 R – RADIUS OF CURVATURE
 ROW – RIGHT OF WAY
 R/W – RIGHT OF WAY
 SMD – SETTLEMENT MONITORING DEVICE
 SSMH – SANITARY SEWER MANHOLE
 STA – STATION
 T – TANGENT LENGTH
 TP – TEST PIT
 TYP – TYPICAL
 UNO – UNLESS NOTED OTHERWISE
 USACE – UNITED STATES ARMY CORPS OF ENGINEERS
 V – VALVE
 VB – VALVE BOX
 VC – VERTICAL CURVE
 VERT – VERTICAL

DO NOT SCALE FROM THESE DRAWINGS USE DIMENSIONS

DESIGNED BY: xxx		STATE OF ALASKA DEPARTMENT OF TRANSPORTATION & PUBLIC FACILITIES SOUTHEAST REGION			
		MARINE SAND POINT DOCK REPLACEMENT PROJECT #SFHWY00006			
		GENERAL NOTES & SPECIFICATIONS			
CHECKED BY: STAFF					
DRAWN BY: STAFF					
PATH: 02 GENERAL NOTES & SPECIFICATIONS.DWG		ALEX MENDOZA			
TAB: 02		Thursday, April 07, 2016 4:51:37 PM			
REVISIONS		PROJECT DESIGNATION		YEAR	TOTAL SHEETS
NO.	DATE	DESCRIPTION			NO.
			SFHWY00006		2016
					2
					XX

20% DESIGN
04/07/16

ESTIMATE OF QUANTITIES			
ITEM NO.	PAY ITEM	PAY UNIT	TOTAL
207(X)	SALVAGED CLASS A ARMOR ROCK	LUMP SUM	ALL REQ'D
207(X)	SALVAGED CLASS B ARMOR ROCK	LUMP SUM	ALL REQ'D
207(X)	CLASS A ARMOR ROCK	LUMP SUM	ALL REQ'D
207(X)	CLASS B ARMOR ROCK	LUMP SUM	ALL REQ'D
203(X)	BORROW	CUBIC YARD	XXX
501(X)	CONCRETE DOCK	LUMP SUM	ALL REQ'D
504(X)	FENDER	EACH	XX
504(X)	BOLLARD	EACH	XX
504(X)	BULLRAIL	EACH	XX
504(X)	DOLPHIN	EACH	XX
504(X)	CATWALK	EACH	XX
505(X)	FURNISH STRUCTURAL STEEL PILES (XX)	LINEAR FOOT	XX
505(X)	DRIVE STRUCTURAL STEEL PILES, (XX)	EACH	XX
505(X)	PILE ANODES	EACH	XX
505(X)	PILE SPLICE	CONTINGENT SUM	ALL REQ'D
615(X)	SIGNS	LUMP SUM	ALL REQ'D
640(X)	MOBILIZATION AND DEMOBILIZATION	LUMP SUM	ALL REQ'D
640(X)	WORKER MEALS AND LODGING, OR PER DIEM	LUMP SUM	ALL REQ'D
641(X)	EROSION, SEDIMENT AND POLLUTION CONTROL ADMINISTRATION	LUMP SUM	ALL REQ'D
641(X)	TEMPORARY EROSION, SEDIMENT AND POLLUTION CONTROL	LUMP SUM	ALL REQ'D
641(X)	TEMPORARY EROSION, SEDIMENT AND POLLUTION CONTROL	CONTINGENT SUM	ALL REQ'D
641(X)	WITHHOLDING	CONTINGENT SUM	ALL REQ'D
642(X)	CONSTRUCTION SURVEYING	LUMP SUM	ALL REQ'D
644(X)	FIELD OFFICE	LUMP SUM	ALL REQ'D
644(X)	VEHICLES	LUMP SUM	ALL REQ'D
645(X)	TRAINING PROGRAM	LABOR HOURS	XXX
649(X)	MARINE MAMMAL AND EIDER OBSERVATION	LUMP SUM	ALL REQ'D

BASIS OF ESTIMATES		
ITEM NO.	ITEM	ESTIMATING FACTOR
207(X)	SALVAGED CLASS A ARMOR ROCK	XX CY/LUMP SUM
207(X)	SALVAGED CLASS B ARMOR ROCK	XX CY/LUMP SUM
207(X)	CLASS A ARMOR ROCK	XX CY/LUMP SUM
207(X)	CLASS B ARMOR ROCK	XX CY/LUMP SUM

20% DESIGN
04/07/16

DO NOT SCALE FROM THESE DRAWINGS USE DIMENSIONS

DESIGNED BY: xxx		STATE OF ALASKA DEPARTMENT OF TRANSPORTATION & PUBLIC FACILITIES SOUTHEAST REGION				
CHECKED BY: STAFF		MARINE SAND POINT DOCK REPLACEMENT PROJECT #SFHWY00006 ESTIMATE OF QUANTITIES				
DRAWN BY: STAFF						
PATH: 03 ESTIMATE OF QUANTITIES.DWG		PROJECT DESIGNATION		YEAR	SHEET NO.	TOTAL SHEETS
TAB: 03 Thursday, April 07, 2016 4:51:49 PM		SFHWY00006		2016	3	XX
ALEX MENDOZA						

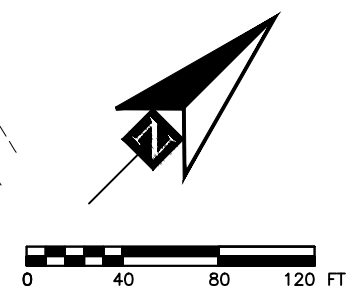
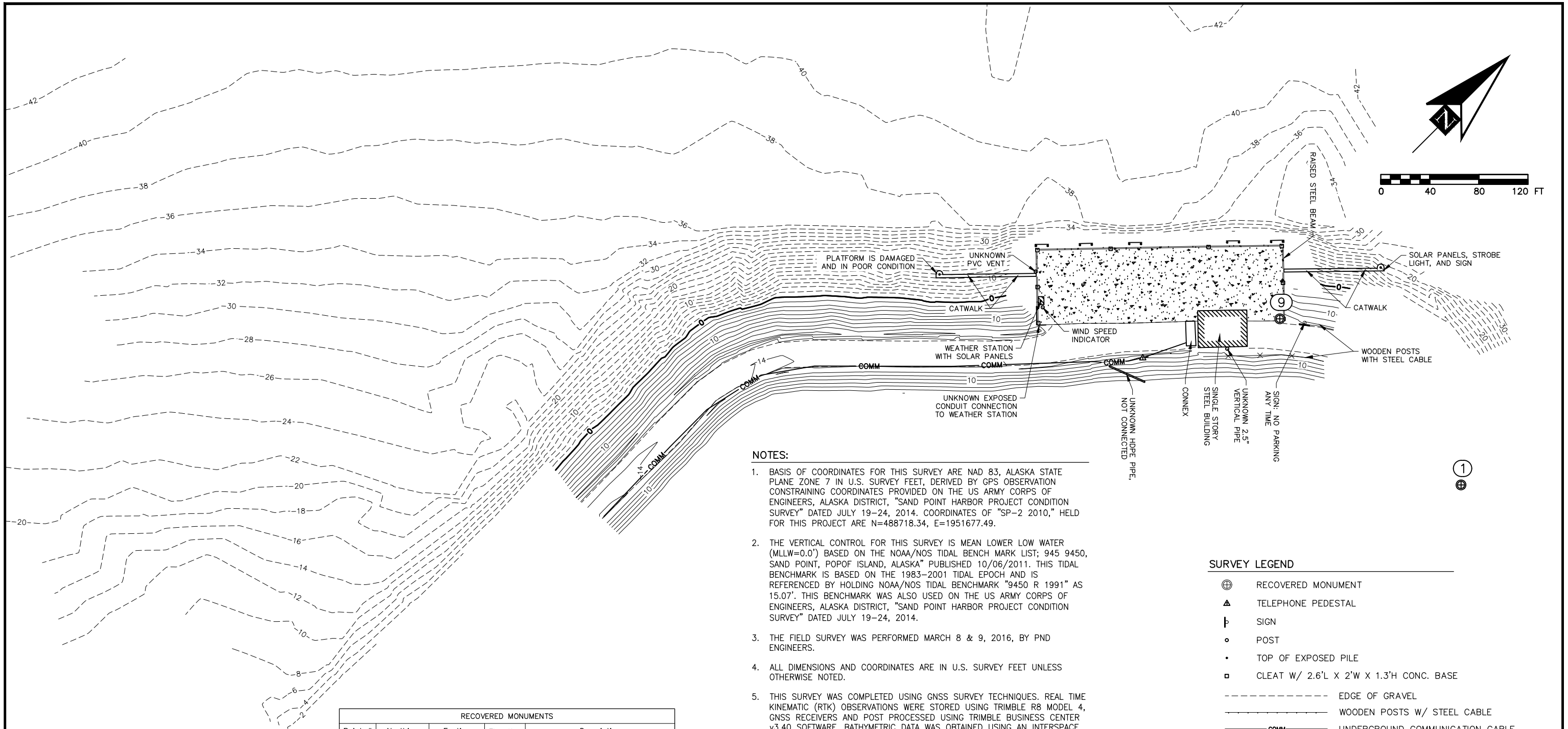

NOTES:

1. BASIS OF COORDINATES FOR THIS SURVEY ARE NAD 83, ALASKA STATE PLANE ZONE 7 IN U.S. SURVEY FEET, DERIVED BY GPS OBSERVATION CONSTRAINING COORDINATES PROVIDED ON THE US ARMY CORPS OF ENGINEERS, ALASKA DISTRICT, "SAND POINT HARBOR PROJECT CONDITION SURVEY" DATED JULY 19-24, 2014. COORDINATES OF "SP-2 2010," HELD FOR THIS PROJECT ARE N=488718.34, E=1951677.49.
2. THE VERTICAL CONTROL FOR THIS SURVEY IS MEAN LOWER LOW WATER (MLLW=0.0') BASED ON THE NOAA/NOS TIDAL BENCH MARK LIST; 945 9450, SAND POINT, POPOF ISLAND, ALASKA" PUBLISHED 10/06/2011. THIS TIDAL BENCHMARK IS BASED ON THE 1983-2001 TIDAL EPOCH AND IS REFERENCED BY HOLDING NOAA/NOS TIDAL BENCHMARK "9450 R 1991" AS 15.07'. THIS BENCHMARK WAS ALSO USED ON THE US ARMY CORPS OF ENGINEERS, ALASKA DISTRICT, "SAND POINT HARBOR PROJECT CONDITION SURVEY" DATED JULY 19-24, 2014.
3. THE FIELD SURVEY WAS PERFORMED MARCH 8 & 9, 2016, BY PND ENGINEERS.
4. ALL DIMENSIONS AND COORDINATES ARE IN U.S. SURVEY FEET UNLESS OTHERWISE NOTED.
5. THIS SURVEY WAS COMPLETED USING GNSS SURVEY TECHNIQUES. REAL TIME KINEMATIC (RTK) OBSERVATIONS WERE STORED USING TRIMBLE R8 MODEL 4, GNSS RECEIVERS AND POST PROCESSED USING TRIMBLE BUSINESS CENTER v3.40 SOFTWARE. BATHYMETRIC DATA WAS OBTAINED USING AN INTERSPACE 448 ECHOSOUNDER.
6. UTILITY LOCATES WERE SURVEYED WHERE MARKED BY LOCATE COMPANIES. THE ONLY UTILITY LOCATES FOUND WERE PROVIDED BY TELALASKA.
7. CONTOURS ARE IN FEET, WITH TWO FOOT INTERVALS.

SURVEY LEGEND

- ⊕ RECOVERED MONUMENT
- △ TELEPHONE PEDESTAL
- ⌵ SIGN
- POST
- TOP OF EXPOSED PILE
- CLEAT W/ 2.6'L X 2'W X 1.3'H CONC. BASE
- - - - - EDGE OF GRAVEL
- — — — — WOODEN POSTS W/ STEEL CABLE
- COMM — UNDERGROUND COMMUNICATION CABLE
- ▒ CONCRETE
- ▨ BUILDING

RECOVERED MONUMENTS				
Point #	Northing	Easting	Elevation	Description
1	489768.320	1952169.160	11.69	FD BC[NOAA]; TIDAL BM
8	488718.340	1951677.490	15.29	FD BC[HUGHES & ASSOC]; 2010
9	489759.564	1951968.833	15.07	FD BC[NOAA]; TIDAL BM 9450S 1991



20% DESIGN
04/07/16

DO NOT SCALE FROM THESE DRAWINGS USE DIMENSIONS

DESIGNED BY: xxx		STATE OF ALASKA DEPARTMENT OF TRANSPORTATION & PUBLIC FACILITIES SOUTHEAST REGION			
		MARINE SAND POINT DOCK REPLACEMENT PROJECT #SFHWY00006			
		SURVEY AND PROJECT CONTROL			
CHECKED BY: STAFF		ALEX MENDOZA			
DRAWN BY: STAFF		TOTAL SHEETS			
PATH: 04 SURVEY AND PROJECT CONTROL.DWG		PROJECT DESIGNATION			
TAB: 04 Thursday, April 07, 2016 4:52:06 PM		YEAR		SHEET NO.	
		2016		4	
REVISIONS		TOTAL SHEETS			
NO.	DATE	DESCRIPTION			
			SFHWY00006 2016 4 XX		



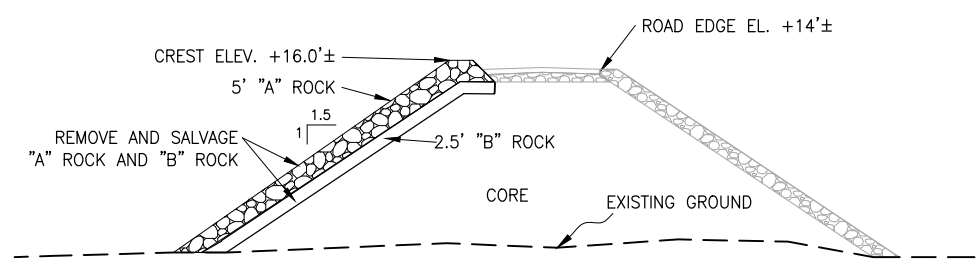
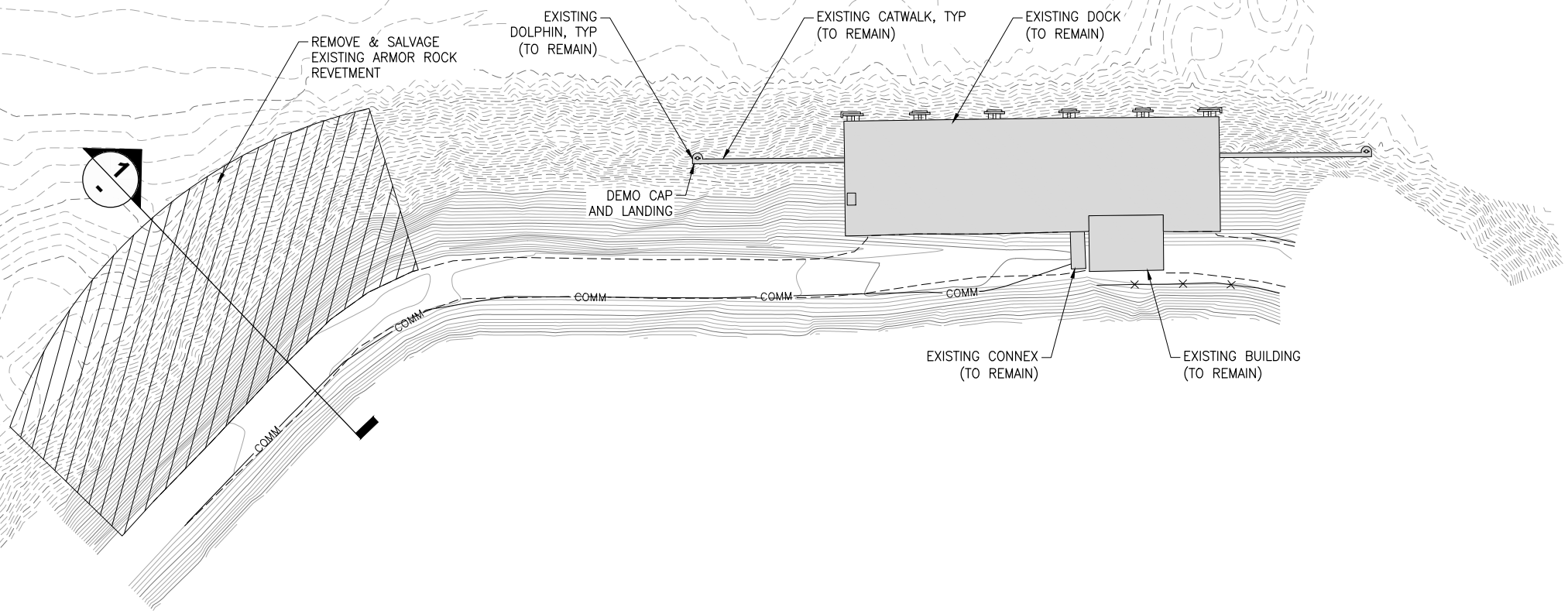
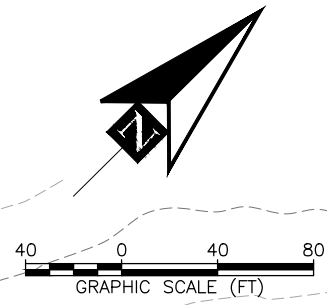

1 CAUSEWAY SECTION

20% DESIGN
04/07/16

DO NOT SCALE FROM THESE DRAWINGS USE DIMENSIONS

DESIGNED BY: xxx		STATE OF ALASKA DEPARTMENT OF TRANSPORTATION & PUBLIC FACILITIES SOUTHEAST REGION			
CHECKED BY: STAFF		MARINE SAND POINT DOCK REPLACEMENT PROJECT #SFHWY00006 EXISTING CONDITIONS & DEMOLITION			
DRAWN BY: STAFF					
PATH: 05 EXISTING CONDITIONS AND DEMOLITION.DWG		PROJECT DESIGNATION		YEAR	TOTAL SHEETS
TAB: 05 Thursday, April 07, 2016 4:52:23 PM		SFHWY00006		2016	XX
REVISIONS		NO.	DATE	DESCRIPTION	

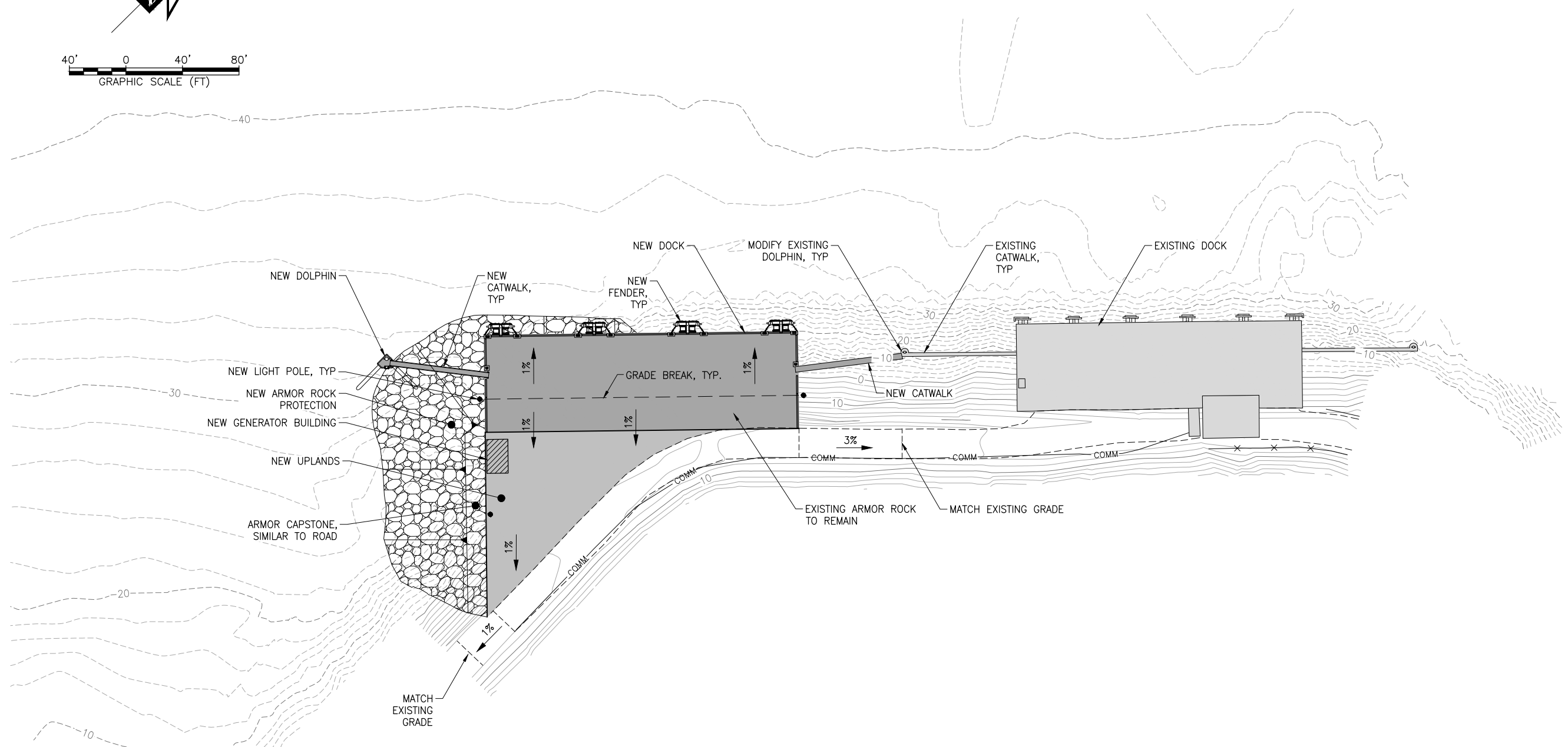
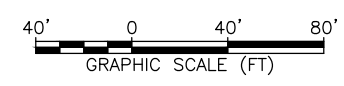
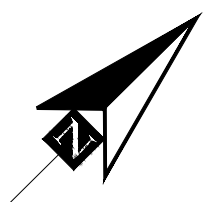

20% DESIGN
04/07/16

DO NOT SCALE FROM THESE DRAWINGS USE DIMENSIONS

DESIGNED BY: xxx		STATE OF ALASKA DEPARTMENT OF TRANSPORTATION & PUBLIC FACILITIES SOUTHEAST REGION			
		MARINE SAND POINT DOCK REPLACEMENT PROJECT #SFHWY00006 SITE PLAN			
CHECKED BY: STAFF					
DRAWN BY: STAFF					
PATH: 06 SITE PLAN.DWG		Thursday, April 07, 2016 4:52:40 PM		ALEX MENDOZA	
TAB: 06					
REVISIONS		PROJECT DESIGNATION		YEAR	SHEET NO.
NO.	DATE	DESCRIPTION	SFHWY00006	2016	6
			TOTAL SHEETS		
			XX		

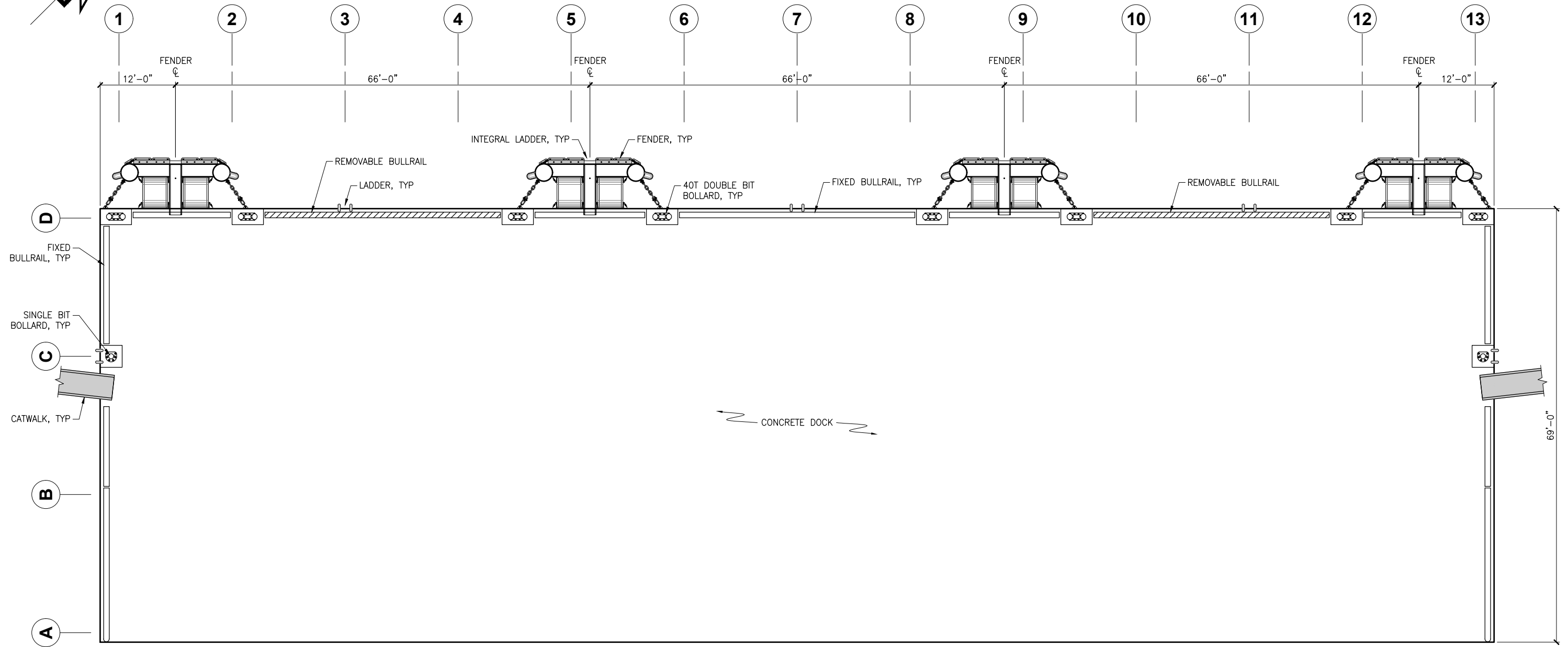
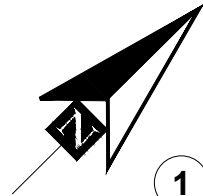

DOCK LAYOUT



20% DESIGN
04/07/16

DO NOT SCALE FROM THESE DRAWINGS USE DIMENSIONS

DESIGNED BY: xxx		STATE OF ALASKA DEPARTMENT OF TRANSPORTATION & PUBLIC FACILITIES SOUTHEAST REGION			
		MARINE SAND POINT DOCK REPLACEMENT PROJECT #SFHWY00006 DOCK LAYOUT			
CHECKED BY: STAFF					
DRAWN BY: STAFF					
PATH: 07 DOCK LAYOUT.DWG		Thursday, April 07, 2016 4:52:52 PM		ALEX MENDOZA	
TAB: 07					
REVISIONS		PROJECT DESIGNATION	YEAR	SHEET NO.	TOTAL SHEETS
NO.	DATE	DESCRIPTION			
			SFHwy00006	2016	7 XX

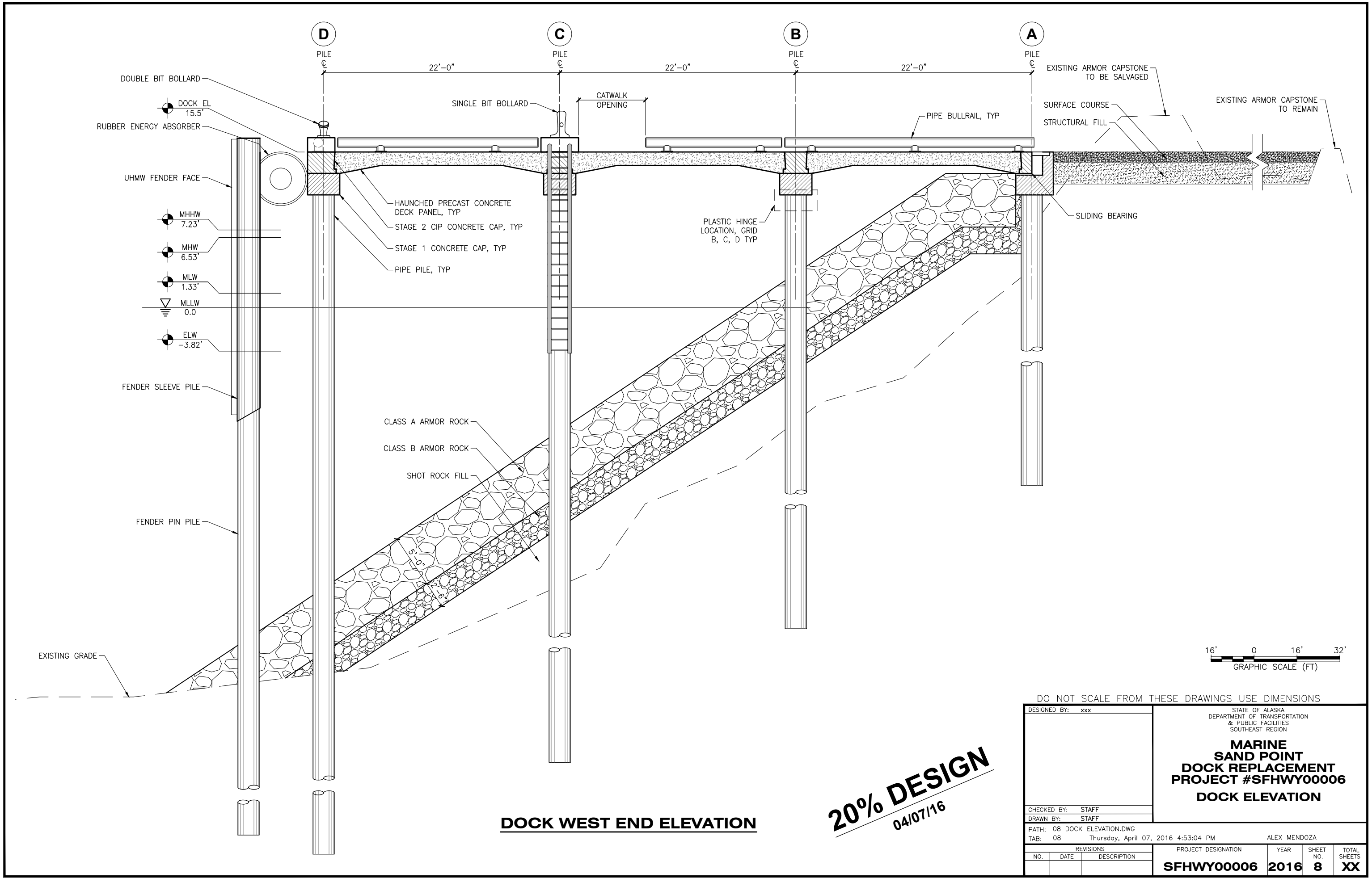

DOCK WEST END ELEVATION

20% DESIGN
04/07/16



DO NOT SCALE FROM THESE DRAWINGS USE DIMENSIONS

DESIGNED BY: xxx		STATE OF ALASKA DEPARTMENT OF TRANSPORTATION & PUBLIC FACILITIES SOUTHEAST REGION			
CHECKED BY: STAFF		MARINE SAND POINT DOCK REPLACEMENT PROJECT #SFHWY00006 DOCK ELEVATION			
DRAWN BY: STAFF					
PATH: 08 DOCK ELEVATION.DWG		Thursday, April 07, 2016 4:53:04 PM		ALEX MENDOZA	
TAB: 08					
REVISIONS		PROJECT DESIGNATION		YEAR	SHEET NO.
NO.	DATE	DESCRIPTION	SFHWY00006	2016	8
			TOTAL SHEETS		
			XX		

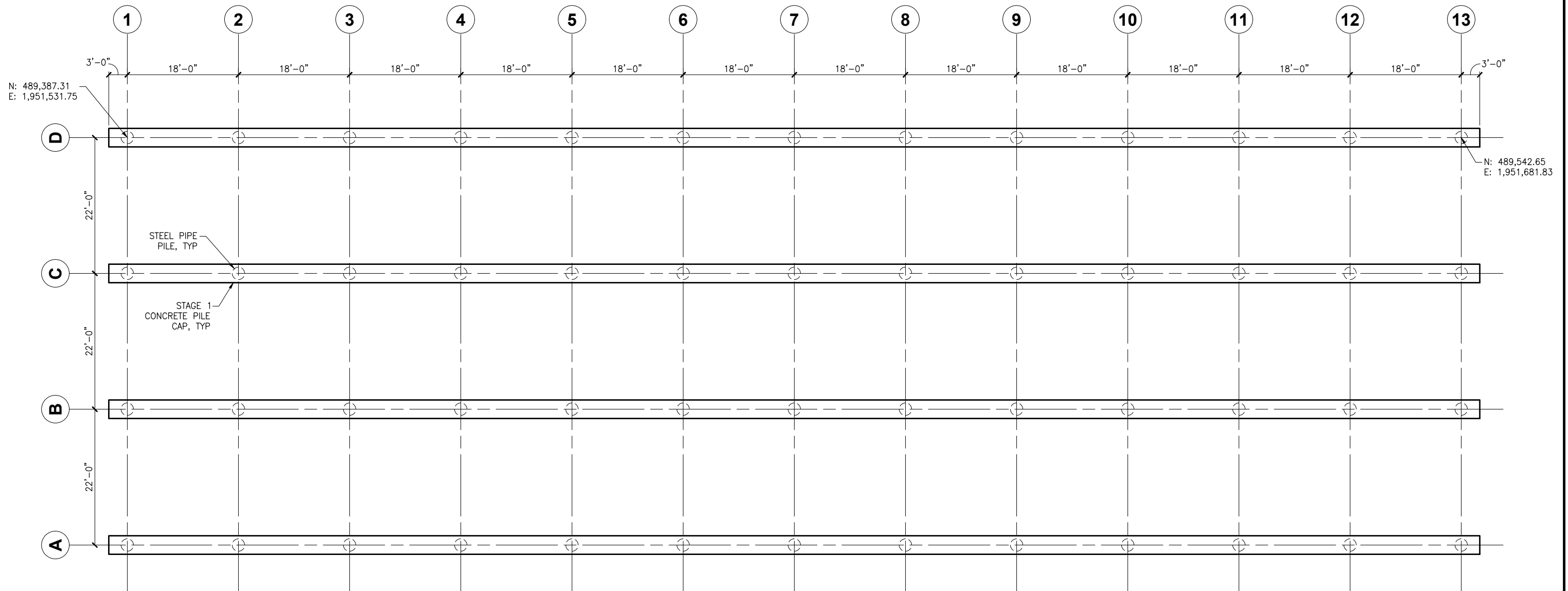
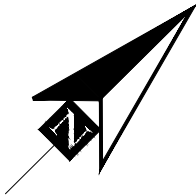

PILE & CAP LAYOUT



20% DESIGN
04/07/16

DO NOT SCALE FROM THESE DRAWINGS USE DIMENSIONS

DESIGNED BY: xxx		STATE OF ALASKA DEPARTMENT OF TRANSPORTATION & PUBLIC FACILITIES SOUTHEAST REGION			
		MARINE SAND POINT DOCK REPLACEMENT PROJECT #SFHWY00006 PILE & CAP LAYOUT			
CHECKED BY: STAFF					
DRAWN BY: STAFF					
PATH: 09 PILE & CAP LAYOUT.DWG		Thursday, April 07, 2016 4:53:15 PM		ALEX MENDOZA	
TAB: 09					
REVISIONS		PROJECT DESIGNATION	YEAR	SHEET NO.	TOTAL SHEETS
NO.	DATE	DESCRIPTION			
			SFHWY00006	2016	9 XX

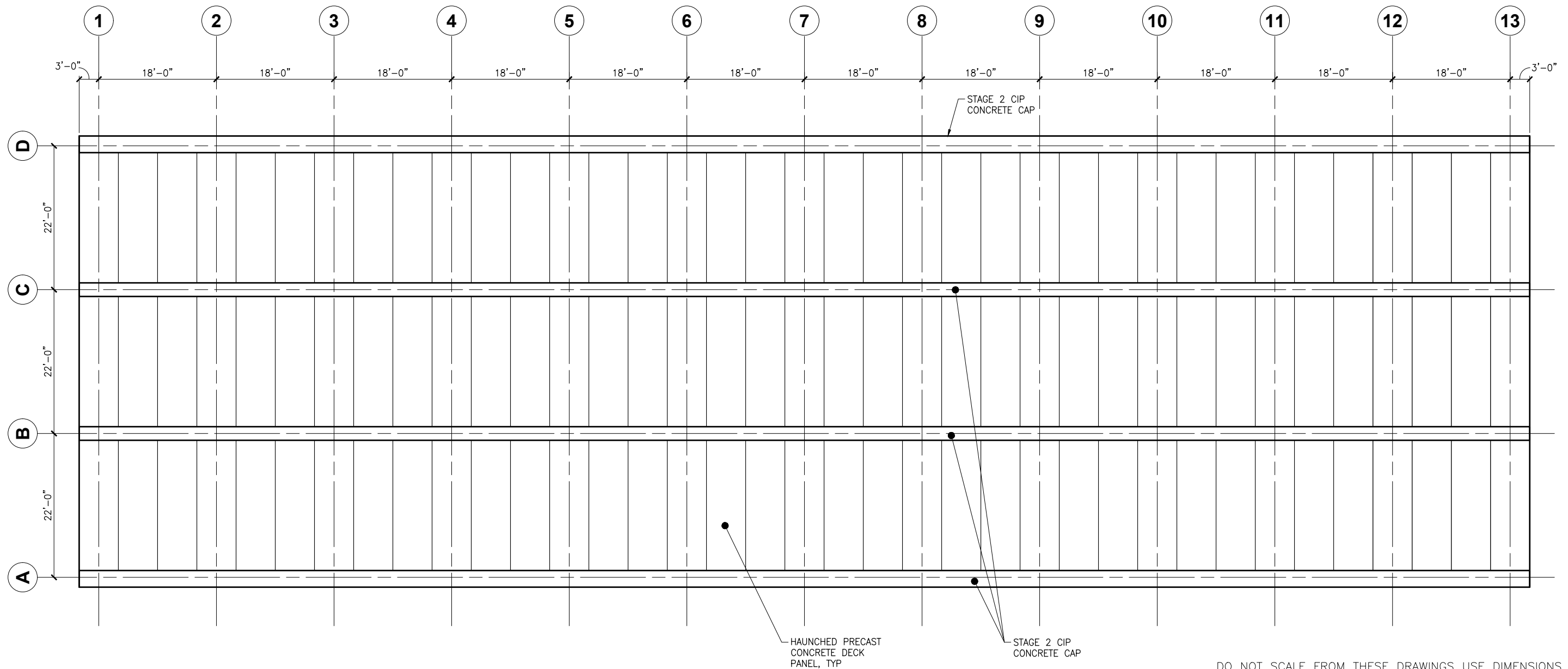
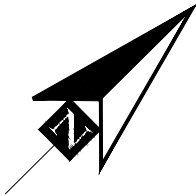

PANEL PLAN



20% DESIGN
04/07/16

DO NOT SCALE FROM THESE DRAWINGS USE DIMENSIONS

DESIGNED BY: xxx		STATE OF ALASKA DEPARTMENT OF TRANSPORTATION & PUBLIC FACILITIES SOUTHEAST REGION			
		MARINE SAND POINT DOCK REPLACEMENT PROJECT #SFHWY00006 PANEL PLAN			
CHECKED BY: STAFF					
DRAWN BY: STAFF					
PATH: 10 PANEL PLAN.DWG		Thursday, April 07, 2016 4:53:27 PM		ALEX MENDOZA	
TAB: 10					
REVISIONS		PROJECT DESIGNATION		YEAR	TOTAL SHEETS
NO.	DATE	DESCRIPTION	SFHWY00006	2016	10 XX

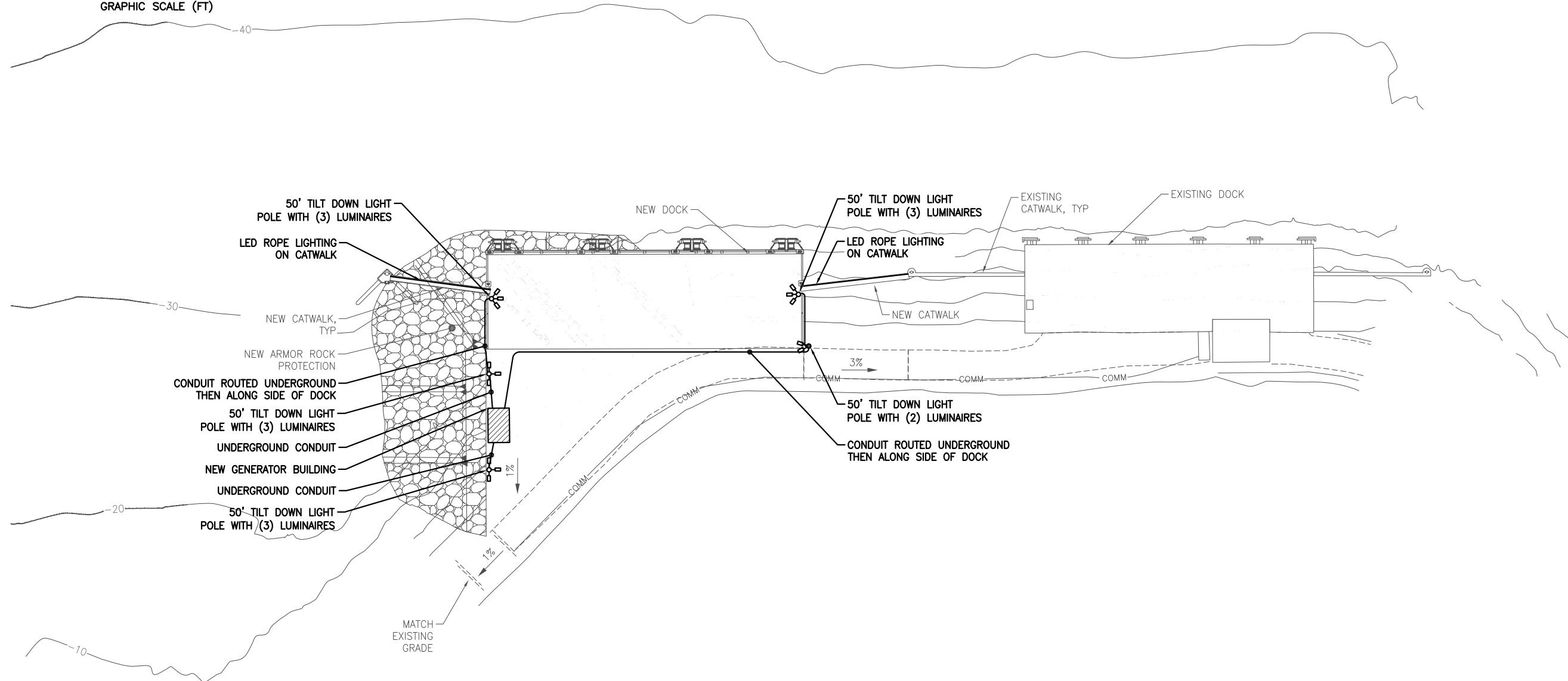
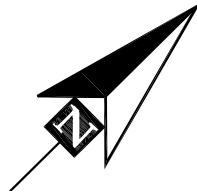

① SITE PLAN - ELECTRICAL

DO NOT SCALE FROM THESE DRAWINGS USE DIMENSIONS

DESIGNED BY: MGM		STATE OF ALASKA DEPARTMENT OF TRANSPORTATION & PUBLIC FACILITIES SOUTHEAST REGION MARINE SAND POINT DOCK REPLACEMENT PROJECT #SFHWY00006 SITE PLAN												
CHECKED BY: MGM														
DRAWN BY: LDS		PROJECT DESIGNATION: SFHWY00006 YEAR: 2016 SHEET NO.: E1 TOTAL SHEETS: XX												
PATH: E3 NEW SITE PLAN.DWG		Thursday, April 07, 2016 2:41:04 PM SHERRELL												
TAB: E1														
<table border="1"> <thead> <tr> <th colspan="3">REVISIONS</th> </tr> <tr> <th>NO.</th> <th>DATE</th> <th>DESCRIPTION</th> </tr> </thead> <tbody> <tr> <td> </td> <td> </td> <td> </td> </tr> </tbody> </table>		REVISIONS			NO.	DATE	DESCRIPTION							
REVISIONS														
NO.	DATE	DESCRIPTION												

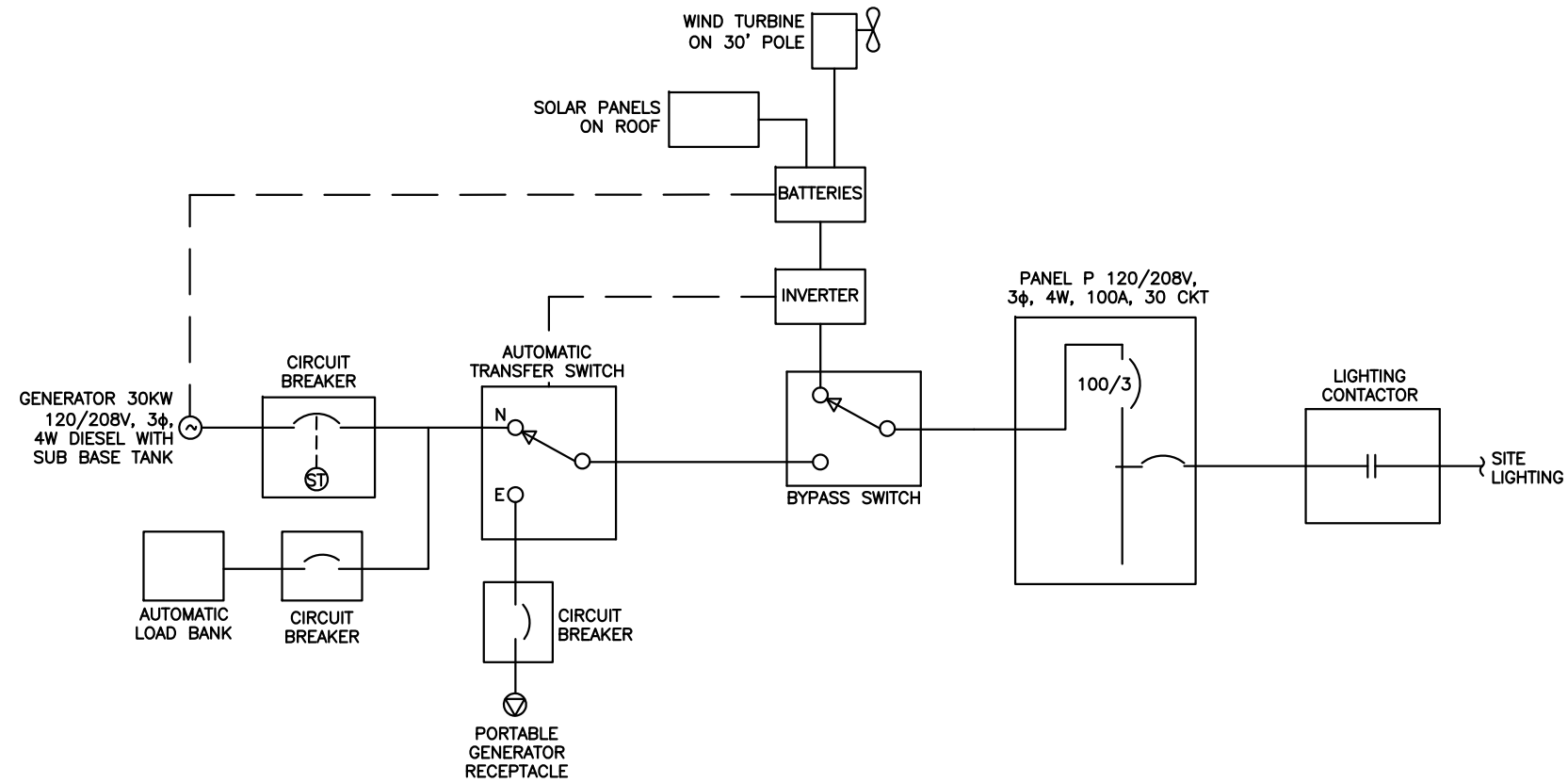

① SINGLE LINE DIAGRAM

DO NOT SCALE FROM THESE DRAWINGS USE DIMENSIONS

DESIGNED BY: MGM		STATE OF ALASKA DEPARTMENT OF TRANSPORTATION & PUBLIC FACILITIES SOUTHEAST REGION			
		MARINE SAND POINT DOCK REPLACEMENT PROJECT #SFHWY00006 SINGLE LINE DIAGRAM			
CHECKED BY: MGM		PROJECT DESIGNATION		YEAR	TOTAL SHEETS
DRAWN BY: LDS		SFHWY00006		2016	XX
PATH: E2 SLD.DWG		THURSDAY, APRIL 07, 2016 2:42:51 PM		LISA SHERRELL	
TAB: E2					
NO.	DATE	DESCRIPTION			

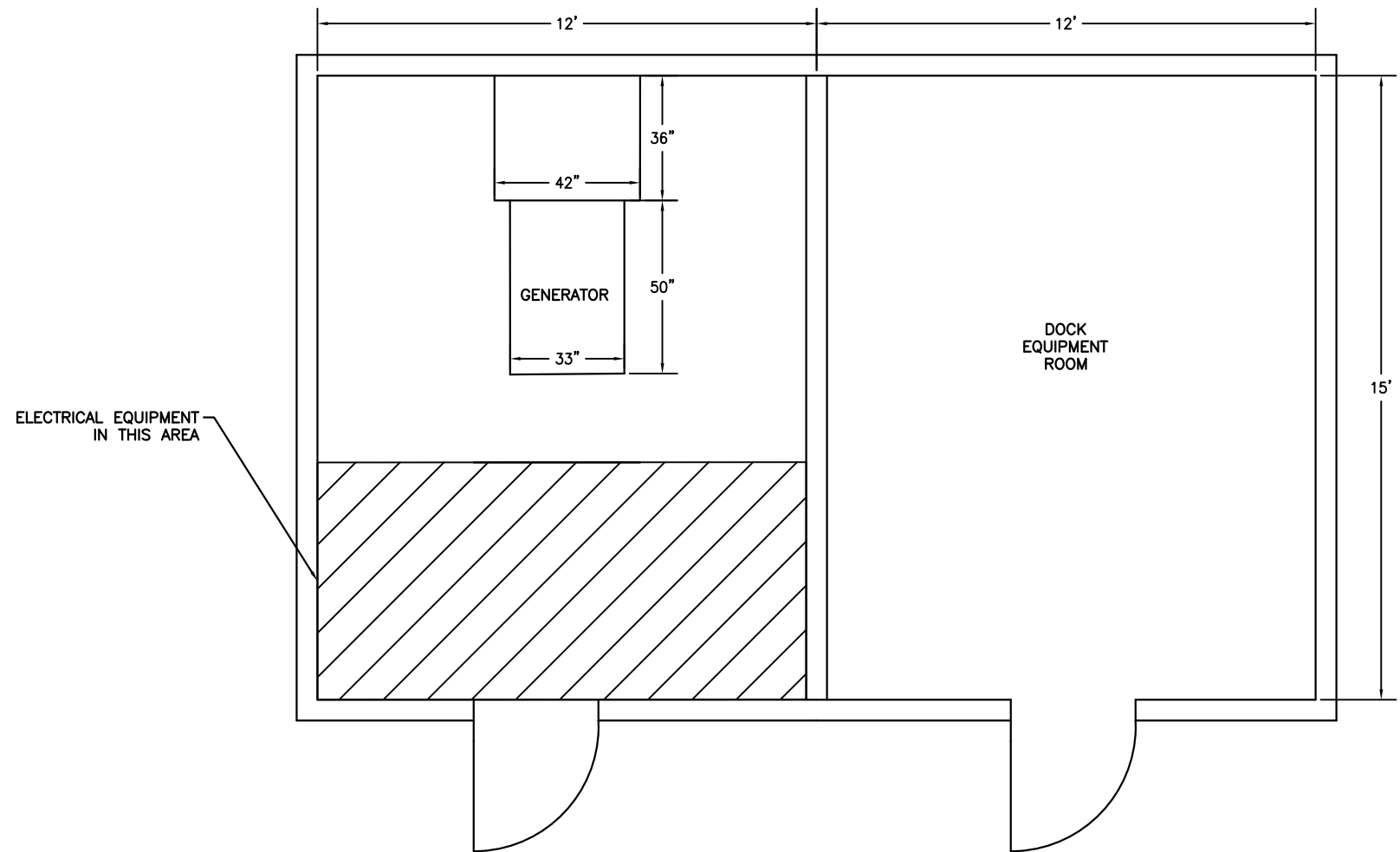
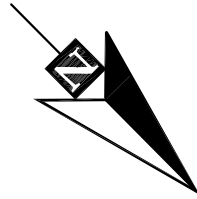

① GENERATOR BUILDING

DO NOT SCALE FROM THESE DRAWINGS USE DIMENSIONS

DESIGNED BY: MGM		STATE OF ALASKA DEPARTMENT OF TRANSPORTATION & PUBLIC FACILITIES SOUTHEAST REGION			
		MARINE SAND POINT DOCK REPLACEMENT PROJECT #SFHWY00006 GENERATOR BUILDING			
CHECKED BY: MGM					
DRAWN BY: LDS					
PATH: E3 GEN BLDG.DWG		Thursday, April 07, 2016 2:42:21 PM		LISA SHERRELL	
TAB: E3					
REVISIONS		PROJECT DESIGNATION		YEAR	SHEET NO.
NO.	DATE	DESCRIPTION	SFHWY00006	2016	E3
			TOTAL SHEETS	XX	

Cost Breakdown Structure (CBS) Register

PND ENGINEERS, INC.

CBS Position Code	Description	Material Quantity	Unit of Measure	Total Unit Cost	Total Cost
JOB	JOB				
1	Pile Supported Dock	13,320.00	SF	\$754.90	\$10,055,331.45
1.1	Mobilization and Demobilization	1.00	LS	\$1,060,551.27	\$1,060,551.27
1.2	Demolition	1.00	LS	\$289,830.28	\$289,830.28
1.3	Provide and Install Pile Supported Dock	1.00	LS	\$2,975,584.71	\$2,975,584.71
1.4	Fender System	4.00	EA	\$201,971.78	\$807,887.11
1.5	Dock Appurtenances	1.00	LS	\$635,278.42	\$635,278.42
1.6	Mooring Dolphin	1.00	EA	\$390,264.11	\$390,264.11
1.7	Fill and Armor Rock	1.00	LS	\$867,093.03	\$867,093.03
1.8	Electrical	1.00	LS	\$305,000.00	\$305,000.00
1.9	Lodging and Per Diem	1.00	LS	\$288,000.00	\$288,000.00
1.10	Construction Survey	1.00	LS	\$97,742.52	\$97,742.52
1.11	Marine Mammal Observation	1.00	LS	\$190,050.00	\$190,050.00
1.12	Construction Adminstration	1.00	LS	\$934,050.00	\$934,050.00
1.13	ICAP (4.79% of Cost Including Construction Admin)	1.00	LS	\$424,000.00	\$424,000.00
1.14	Contingency (Assumed 10%)	1.00	LS	\$790,000.00	\$790,000.00
16					\$10,055,331.45

Eastern Aleutian Tribes
Executive Director Report
Jennifer Harrison
March 2016



Nome Hospital with attached Nursing Assisted Living Facility

Service

- **Adak - Upcoming Services:**
 - April 14 – 17th – EAT Board Meeting
 - May 2 – 6th – SCF Village Doc, Summer Cuttings

- **Akutan - Upcoming Services:**
 - April 25 – 29th – Suzanne, BBNHC Tobacco Cessation Specialist
 - June 20 – 25th – SCF Optometrist, Dr. Lesniak

- **Cold Bay - Upcoming Services:**
 - April 15 – 21st – Dr. Koehler
 - May 2 – 3rd – SCF Optometrist, Dr. Lesniak
 - May 13 - 14th – SCF Optometrist, Dr. Humphreys and Optician

- **False Pass - Upcoming Services:**
 - April 4 – 8th – Dr. Koehler
 - May 16 – 18th – Dr. Leoncio, SCF Village Doc

- **King Cove - Upcoming Services:**
 - March 11 – April 5th - Dr. Costa, Dentist, and Gaby Costa, Dental Assistant
 - April 18 – 23rd – SCF Village Doc, Dr. Saunders
 - May 9 – 13th – SCF Optometrist Dr. Humphreys and Optician

- **Nelson Lagoon - Upcoming Services:**
 - March 19 – 26th - Ben Steward, DHAT
 - May 3 – 6th – SCF Optometrist, Dr. Lesniak
 - May 19 – 21st – SCF Village Doc, Dr. Leoncio

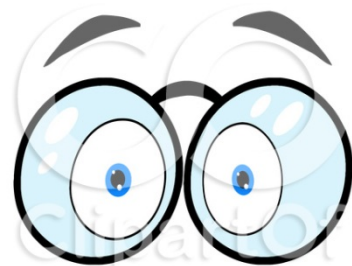

www.clipartof.com · 434728

- **Sand Point - Upcoming Services:**

- April 7 – 9th – Carrie Plant, Spout Family Services
- April 11 – 15th – SCF Optometrist, Dr. Palma, with Geri, Optician
- April 18 – 23rd – SCF Dentist
- April 25 – 29th – Jennifer Harrison, Executive Director
- April 25 – 29th – SCF Village Doc, Dr. Hartman
- April 26-28th – ANTHC Oncology (cancer) Doctor – Dr. Olnes
- April 27th – Potluck with presentations by Dr. Hartman on Opioid treatments and Dr. Olnes on Oncology/cancer
- May 17 – June 17th – Dr. Smith

- **Whittier - Upcoming Services**

- April 29th – SCF Optometrist, Dr. Rennard



- Caught Ya' Caring Winners for February/March:

- **Leann Mack** (Coding Specialist, Anchorage) – Leann (along with Trisha and Carol) for the largest three month collection of patient revenues over the past three years. Thanks.
- **Dr. Costa** (Dentist) – Dr. Costa (along with Gabby) for their compassionate care. They work extremely hard to make sure that all of the patients that need to be seen “Get Seen”, even if it means they make appointments after work hours to help. It is obvious in the way they treat patients that they care about their jobs and the people they provide care for. Thank you Dr. Costa and Gabby, you are an awesome team!
- **Eileen Owen-Williams** (Itinerant NP, Whittier) – Thank for coming to Whittier to cover the clinic while Olivia is out on PTO. I cannot say enough good things about her. She has been taking care of our patients’ general wellness and has been more involved in the patient care and the community than any of my clinic providers. I have not seen a provider spend her personal time to visit a community member in the hospital or an elder that was recently moved to an assisted living facility. We need to find more people like her in our organization. You know I rarely make a comment on anything, but she was a good fit. Thank you!

Service Highlights:

- **EAT** was accepted in the CMS’ Million Hearts Program. This will provide EAT with better processes for taking care of our patients at risk of dying from heart attack or stroke.
- **Doug Finney** has decided to go back to college. His last full-time day is April 29th. We will try to keep him engaged with us as long as possible to ensure a smooth transition and that CHA’s needs for certification and training are kept up-to-date. **Eileen Owen-Williams** will be the new CHAP Director.
- We have found an excellent dental hygienist and we are working on an itinerant contract with her. **Dental cleanings coming soon!**

- Two Behavioral Health and Wellness **clients successfully entered substance abuse treatment.**
- The Medical Home Coordination Department continues to ensure **smooth transitions of care between our clinics and Alaska Native Medical Center** and assist with end of life transitions when needed.

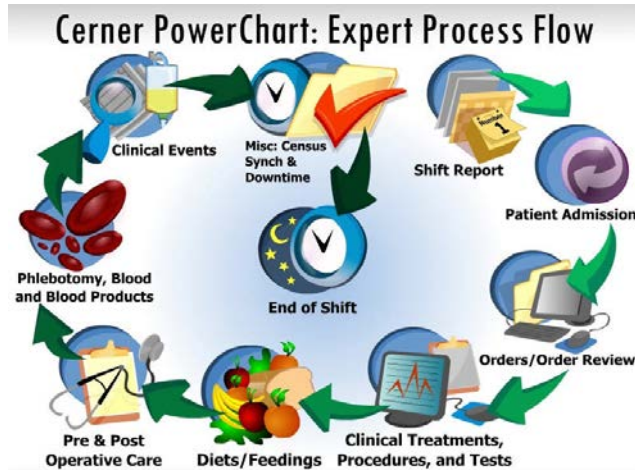

- EAT is on track to “Go Live” with Cerner in May 2016. This is the same electronic health record that Southcentral Foundation and Alaska Native Tribal Health Consortium use.

- The weeks of April 18th and 25th will be training dates for Cerner.

People

- Welcome our New Hires:
 - **Nanette Johnson**, BHA/CIC in Nelson Lagoon (first day March 14th)
- Open Positions:
 - **Behavioral Health Aides/CHR*** – Akutan (An itinerant is working in Akutan, but she could help other villages if we could fill this position with a full-time person.)
 - **Behavioral Health Clinician** – Sand Point
 - **Clinical Information Clerk (CIC)/Janitor*** - Akutan
 - **Community Health Aides*** – Adak and Nelson Lagoon
 - **CIC/Community Health Representative (CHR)*** – Akutan
 - **House Coordinator/Behavioral Health Aide (BHA)*** – Sand Point
 - **Immersive Learning and Education Program Manager** – Any Site
 - **Janitor (intermittent)*** - Adak
 - **Nurse Practitioner/Physician Assistant** – Adak, Akutan, King Cove, Sand Point, and recruiting for Itinerants
 - **Physician** – King Cove, Sand Point, and recruiting for itinerants
 - **Planning and Development Manager** – Any Site

*Note: No experience necessary. Training will be provided.

Quality:

- There will be a **HRSA On-Site Visit on April 25-28th**. Besides spending time in the Anchorage Office, they will be traveling to Sand Point on April 25-26th.
- We have a newly formed Safety and Infection Control Committee that meets monthly to promote health and safety in the workplace.

Growth:

- Robin Gould-Medina, Special Projects/Grants Manager traveled with ELE Consulting to King Cove and False Pass in February to work on the feasibility study for employment-based intensive out-patient substance abuse treatment. ELE Consulting expects to have the feasibility study done by the end of April.
- We submitted for a HRSA Oral Health Expansion grant that would enable us to hire a second Dentist.

Program / Project	Funding Agency	Total Request
HRSA Oral Health	HRSA	\$350,000
Family Violence Prevention (FVPSA)	ACF	\$100,000

Program/Project Name	Funding Agency	Total Amount Funded
Special Diabetes (SDPI)	IHS	\$125,853 (\$20,000 increase)

Report on Events:

On March 14 – 21, I visited Nome, Alaska on my own dime for PTO and a little work.

Highlights:

- I visited the Norton Sound Health Corporation’s Physical Therapy Department and learned about how they are doing **physical therapy via Vidyo** to their clinics. I will continue to encourage ANTHC to do the same for our region. (See picture on right.)



What is cancer of the colon and rectum?

Cancer is a growth inside your body that should not be there. Cancer in the colon and rectum is often called colorectal cancer. But in this brochure we use the term colon cancer to mean both colon and rectum cancers.

Most colon cancers start from polyps (see picture inside) in the colon or rectum, shown in blue in the drawing inside. Over time, polyps can turn into cancer.

Is colon cancer common among Alaska Natives?

Yes, colon cancer occurs more often among Alaska Natives than among other racial or ethnic groups. Most of the time, colon cancer is found in people age 50 or older, but people younger than 50 can get it, too.



What are the symptoms of colon cancer?

In the early stages of colon cancer, there are often no symptoms. This means that someone could have colon cancer and not know it. That is why it is important to be tested regularly. Of course, colon cancer can sometimes have symptoms:

- blood in or on the bowel movement
- a change in bowel habits, such as having diarrhea or being constipated
- bowel movements that are thinner than usual
- pain, aches, or cramps in the abdomen that you can't explain
- frequent gas pains
- losing weight for no reason you know of



Many other health problems can cause these symptoms, too. If you have any of these symptoms, see your doctor. Only your doctor can tell you why you're having them.

Who should get a colon cancer screening test?

If you are 50 or older, you should start getting regular tests for colon cancer. There are different kinds of screening tests. Talk with your doctor about which test you should get. Tests can find polyps and can also find colon cancer early. When colon cancer is found early, medical treatment works best and can save your life.

Does someone in your family have colon cancer?

You have a greater chance of developing colon cancer if someone in your family has had colon cancer or polyps. So it is very important to tell this to your doctor. Your doctor may want to test you earlier (before age 50) and more often than other people.

Terms you may hear your doctor say

Colon

The same thing as the large intestine. It is about six feet long. Food you eat passes through the colon, where it turns into waste matter, or bowel movement.

Polyp

A growth inside the colon or rectum that is not normal. [See the picture to the left.] These growths sometimes turn into cancer if they are not removed.

Rectum

The last eight to ten inches of the large intestine. Bowel movements travel through the rectum and pass out of the body through the anus.

Gastroenterologist

A doctor who is an expert on diseases of the colon, rectum, stomach, and small intestine.

Screening tests for colon cancer

Fecal Occult Blood Test (FOBT)

This test looks for hidden blood in your bowel movement. For three bowel movements in a row, you place a small piece of bowel movement on a card. Then you return the card to the doctor, and the doctor tests to see if there is blood.

Blood in the stool can be a sign of colon cancer, but several other things may cause blood to be in the bowel movement. Some of these things may be more common to Alaska Natives and include:

- Eating Native and other meats before the test
- Bleeding from the stomach or other places in your body
- A common stomach germ, called H. pylori, that can cause bleeding

For these reasons, this test may not be the first choice for Alaska Natives. Talk to your doctor about having this test.

Sigmoidoscopy

This test looks for polyps in the lower part of the colon. A doctor puts a short, flexible tube inside the anus and lower part of the colon to allow him or her to see inside. This test should usually be done every five years.



Polyp in Colon

Colonoscopy

This test looks for polyps in the entire colon. A doctor puts a long, flexible tube inside the anus and in the entire colon to allow him or her to see any polyps inside. Most polyps can be removed during the test. This test is usually done every 10 years.

Double Contrast

Barium Enema

This test is an x-ray of the colon. You will have an enema with a white liquid called barium. Then the doctor will take an x-ray. The barium makes it easy for the doctor to see the outline of the colon on the x-ray. This test is usually done every 5-10 years.

